

P R E M I U M



C O F F E E

M A C H I N E S



COTI
by CRANE

CALI
by CRANE

ICON
by CRANE

Technical Manual

Part Number: PR15937000

Issue: C - 01/2019

EC Declaration of Conformity

We Crane Merchandising Systems (UK),

Of Pipsmore Park, Bumpers Farm Industrial Estate, Chippenham, Wiltshire, UK,
SN14 6NQ

Declare that:

Type of Equipment: Beverage Vending Machine
Model Name: COTI / CALI / ICON

Has been designed and manufactured to comply with all essential requirements of the following Regulations/Directives:

2006/95/EEC	<u>The Low Voltage Directive</u> and its amending directives
2004/108/EEC	<u>The Electromagnetic Compatibility Directive</u> and its amending directives
REG. (EC) 1935/2004	on materials and articles intended to come into contact with food relating to plastic materials and articles intended to come into contact with food stuffs
REG. (EC) 10/2011	

The Essential Requirements of the European regulations for CE marking application are:

1. Mechanical resistance and stability
2. Safety in case of fire
3. Hygiene, health and the environment
4. Safety in use
5. Protection against noise
6. Energy economy and heat retention

Tests have been performed by accredited certification bodies in accordance to the following specifications:

Low Voltage Directive:	EN 60335-1:2002+A1:2004+A11:2004+A12:2006+A2:2006+A13:2008 EN 60335-2-75:2004+A1:2005+A11:2006+A2:2008+A12:2010
EMC Directive:	EN 55014-1:2006+EN55014+A1:2009+A2:2011 EN 55014-2:1997+A120 EN 61000-3-2:2006+A1/A2:200 EN 61000-3-3:2008 EN 61000-4-2:2009 EN 61000-4-3:2012 EN 61000-4-4:2004 EN 61000-4-5:2006 EN 61000-4-11:2010

With regard to hygiene for foodstuffs in location, the operator must comply with 852/2004/EEC which lays out the general and specific hygiene rules to ensure a high level of consumer protection with regard to food safety.



Gillian White
Vice President, General Manager Global Coffee
Date: 01/01/2019:

The following Symbol is used throughout this Manual:



Safety First! Take care, risk of personal injury.

Crane Merchandising Systems accepts no responsibility for damage caused to the equipment through misinterpretation or misuse of the information contained in this manual.

© Copyright 2019 Crane Merchandising Systems

Introduction

This manual provides you with guidance on the installation, daily operation and basic maintenance of your COTI/CALI/ICON freestanding vending machine. Crane Merchandising Systems always recommend that a trained technician service its equipment.

Crane Merchandising Systems is committed to continuous product improvement. This means that the information within this document although correct at time of publication, is for guidance only and may be subject to change without prior notice.

Important Safeguards

Always follow these basic safety precautions when operating or maintaining your machine:

1. Ensure that you and anyone who operates or maintains your machine have this manual available for quick and easy reference, read all instructions carefully before commencing work.
2. **Beware of Electricity** Certain maintenance operations require your machine to remain connected and switched on. Only trained personnel should carry out these routines, and independently of all other operations. Observation of safe working practices in accordance with current regulations is necessary at all times.



Important! Unless otherwise specified always disconnect your machine from the electricity supply before commencing work.

3. Servicing the Heater Tank/Espresso pressurised water system



Important! Water in this machine can exceed 99°C. Water at this temperature can cause severe injury. Espresso machines may be fitted with a pressurised water system, under no circumstance should this be dismantled other than by a fully trained engineer.

4. Do not operate your machine if any part is damaged until a service technician has carried out necessary repairs and ensured that it is safe.
5. Beware of moving components when servicing the machine.
6. Allow your machine to cool before handling or moving.
7. Never immerse your machine in water or any other liquid and never clean it with a water jet.
8. If your machine should freeze up, call a service technician before switching it back on.
9. In machines fitted with carbonator units the CO₂ bottle is filled with gas at up to 800psi and MUST be secured in an upright position. In the event of a leak, ventilate the area in the vicinity
10. Ensure that you are familiar and adhere to the most recent Health and Safety at Work and Electricity at Work Regulations.



Important! This appliance is not intended for use by persons (including children under 8 years old and the infirm) with reduced physical, sensory or mental capabilities or lack of experience and knowledge. Unless they have been given supervision or instruction concerning use of the appliance by a person responsible for their safety and they fully understand the hazards involved.

Children should be supervised to ensure that they do not play with the appliance.

Children must not carry out any cleaning or maintenance of the machine.

Your COTI/CALI/ICON machine is for indoor use only and because it is a beverage machine should be sited in a clean and hygienic area.

Table of Contents

Section 1 - Machine Specifications	1
1.1 Specifications - COTI	1
1.2 Specifications - CALI	2
1.3 Specifications - ICON	3
1.4 Water Filter	4
1.5 External Features - COTI	5
1.6 External Features - CALI	6
1.7 External Features - ICON	7
1.8 Internal Features - COTI / CALI	8
1.9 Internal Features - ICON	9
Section 2 - Installation	10
2.1 Siting Your Machine	10
2.2 Connecting the Water Supply	11
2.3 Connecting the Electrical Supply	12
2.4 Commissioning Procedure	13
2.5 Setting Up the Carbonator Unit (Where Fitted)	18
2.6 Cup Drop Unit Set Up	20
2.7 Stick Stirrer Adjustment (Where Fitted)	21
2.8 Warranty Card	22
Section 3 - Navigation and Programming Mode	23
3.1 Navigation - COTI	23
3.2 Navigation - CALI / ICON	24
3.3 Program Entry	25
3.4 Navigating through the Menu Display	25
3.5 Accessing the Programming Mode	26
3.6 Entering or Updating Parameters	26
Section 4 - Customising the User Interface	28
4.1 Images	28
4.2 Image Locations - COTI	29
4.3 Image Locations - CALI / ICON	31
4.4 USB Stick Contents	33
4.5 Copy USB Stick Contents	33
4.6 Select the Image for Display	35

4.7 Remove Content from Machine..... 37

4.8 Edit the Product Name and Description 38

4.9 Configure Generic Content 39

4.10 Standby Screen 40

4.11 Allergens 45

4.12 Nutrition Info 46

4.13 Operator Manuals 49

4.14 ADA Mode (COTI machine only) 49

4.15 Additional User Interface Options 49

Section 5 - Engineer’s Program 51

5.1 Menu Structure Overview 51

5.2 Main Menu 56

5.3 Data Recall 56

5.4 Diagnostics 59

5.5 Test 60

5.6 Price 65

5.7 Product Configuration 67

5.8 Menu Setup 77

5.9 Free Vend 78

5.10 Money 78

5.11 System Settings 82

5.12 Security Codes 90

5.13 Timed Events 91

5.14 Telemetry 93

5.15 Leave Service Application 93

5.16 Machine Reboot 93

Section 6 - Service Keypad Functions 94

Section 7 - Technical Information 97

7.1 Water Services 97

7.2 Hot Water System 97

7.3 Ingredient Dispense 97

7.4 Mixing System 98

7.5 Moving Dispense Head 98

7.6 Cup Dispense Unit 98

7.7 Waste Level Probes 99

7.8 CoEx Brewer (Espresso Machines)	99
7.9 Oltre Brewer	99
7.10 Power Supply Units	100
7.11 Mains Filter	101
7.12 Coin Mechanism Transformer (Optional Extra)	101
7.13 Coin and Card/Key Systems	101
7.14 Change Giver	101
7.15 Card/Key System	101
Section 8 - Espresso System	102
8.1 Example Vend	102
8.2 System Overview	102
Section 9- Dispense Pipe Lengths	106
9.1 To Replace Pipes	106
Section 10 - Diagnostics and Maintenance Procedures	108
10.1 Diagnostics	108
10.2 Heater Tank De-Scale Procedure	114
10.3 System Drain Down - Espresso Machines Only	115
10.4 CoEx Brewer/Bean Grinder Maintenance - Espresso Machines ...	117
Section 11 - Electrical/Electronics Information	122
11.1 Touch Screen - COTI	122
11.2 Touch Screen - CALI / ICON	123
11.3 Control Board - Atlas H Board	124
11.4 Control Board Connections - Atlas H Board.....	125
11.5 Input/Output Board.....	127
11.6 Input Circuit 1.....	128
11.7 Input Circuit 2.....	129
11.8 Output Circuit 1.....	130
11.9 Output Circuit 2.....	131
11.10 Power Circuit - Instant & Freshbrew Machines	132
11.11 Power Circuit - Espresso Machines	133
11.12 Heater Circuit	134

Section 1 - Machine Specifications

1.1 Specifications - COTI

General			
Height	1830 mm	Depth	785 mm
Width	700 mm	Weight	184 kg
Cup Capacity			
Cup Type		Cup Capacity *	
150ml plastic squat	7oz plastic squat	800	
150ml plastic tall	7oz plastic tall	750	
150ml paper tall	7oz paper tall	665	
180ml plastic	9oz plastic	650	
180ml paper	9oz paper	575	
250ml paper	12oz paper	400	
*Approximate and are for guidance only.			
Electrical Services			
Voltage	220 - 240 Volts		
AC Current	13 Amp Fused		
Frequency	50/60 Hz		
Water Services			
Pressure	200 kPa (2 Bar) - 600 kPa (6 Bar)		
Stopcock	15 mm BSP from rising main		
All weights and dimensions are approximate and are for guidance only.			
Sound Levels			
A-weighted sound pressure level is below 70dB.			



1.2 Specifications - CALI

General			
Height	1830 mm	Depth	785 mm
Width	700 mm	Weight	184 kg
Cup Capacity			
Cup Type		Cup Capacity *	
150ml plastic squat	7oz plastic squat	800	
150ml plastic tall	7oz plastic tall	750	
150ml paper tall	7oz paper tall	665	
180ml plastic	9oz plastic	650	
180ml paper	9oz paper	575	
250ml paper	12oz paper	400	
*Approximate and are for guidance only.			
Electrical Services			
Voltage	220 - 240 Volts		
AC Current	13 Amp Fused		
Frequency	50/60 Hz		
Water Services			
Pressure	200 kPa (2 Bar) - 600 kPa (6 Bar)		
Stopcock	15 mm BSP from rising main		
All weights and dimensions are approximate and are for guidance only.			
Sound Levels			
A-weighted sound pressure level is below 70dB.			



1.3 Specifications - ICON

General			
Height	1830 mm	Depth	790 mm
Width	700 mm	Weight	193 kg
Cup Capacity			
Cup Type		Cup Capacity *	
150ml plastic squat	7oz plastic squat	800	
150ml plastic tall	7oz plastic tall	750	
150ml paper tall	7oz paper tall	665	
180ml plastic	9oz plastic	650	
180ml paper	9oz paper	575	
250ml paper	12oz paper	400	
*Approximate and are for guidance only.			
Electrical Services			
Voltage	220 - 240 Volts		
AC Current	13 Amp Fused		
Frequency	50/60 Hz		
Water Services			
Pressure	200 kPa (2 Bar) - 600 kPa (6 Bar)		
Stopcock	15 mm BSP from rising main		
All weights and dimensions are approximate and are for guidance only.			
Sound Levels			
A-weighted sound pressure level is below 70dB.			



1.4 Water Filter

If your machine is fitted with a CoEx® Espresso and/or Oltre Freshbrew brewer, then it must be connected to the water supply via a scale inhibiting water filter. Crane Merchandising Systems recommend and supply the Brita and 3M ranges of water filters.

1.5 External Features - COTI

Key:

- | | | | |
|---|------------------|----|-----------------|
| 1 | Door | 6 | Drip Tray |
| 2 | Touch Screen | 7 | Adjustable Foot |
| 3 | Door Lock | 8 | Coin Entry |
| 4 | Cup Station | 9 | Cup Stand |
| 5 | SureVend™ Sensor | 10 | Coin Return Cup |

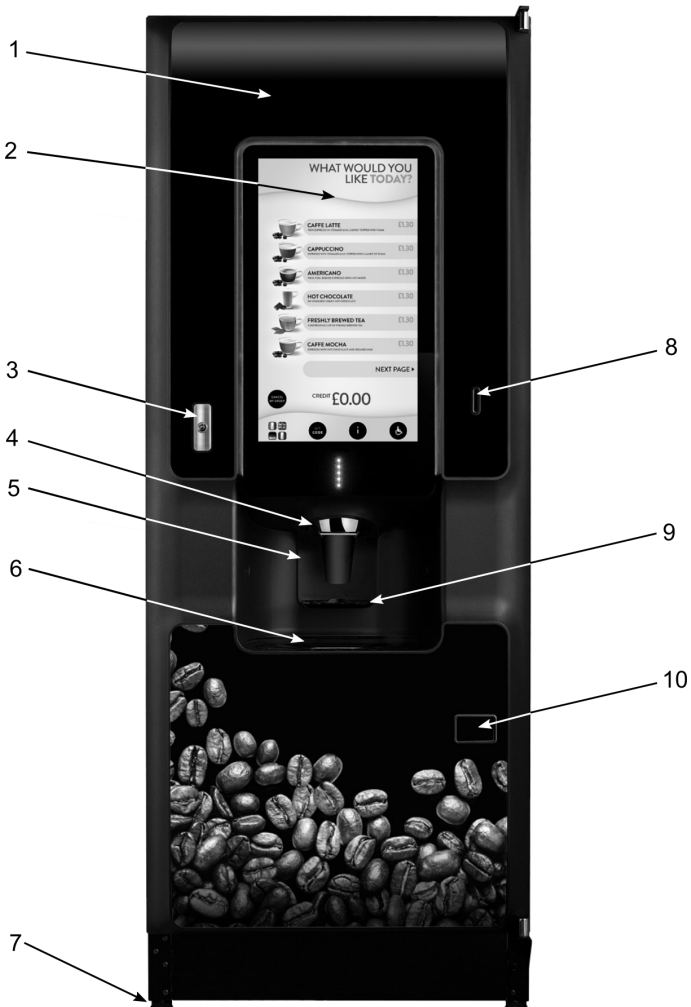

1.6 External Features - CALI

Key:

- | | | | |
|---|----------------------|----|------------------|
| 1 | Door | 6 | SureVend™ Sensor |
| 2 | Display Screen | 7 | Drip Tray |
| 3 | Drink Selection Menu | 8 | Adjustable Foot |
| 4 | Door Lock | 9 | Coin Entry |
| 5 | Cup Station | 10 | Cup Stand |
| | | 11 | Coin Return Cup |

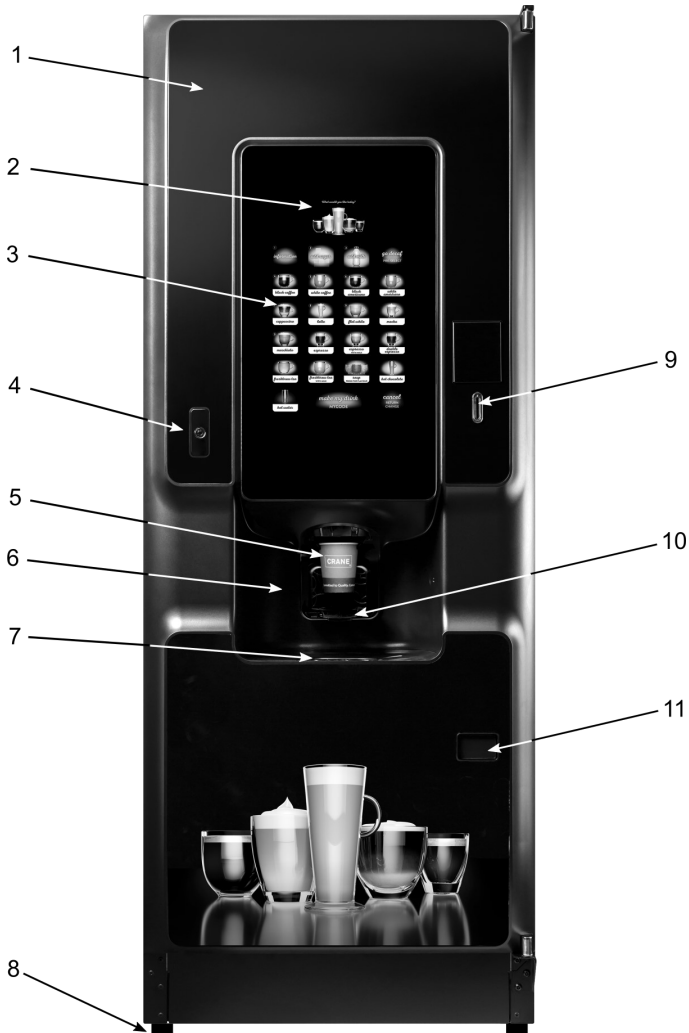

1.7 External Features - ICON

Key:

- | | | | |
|---|----------------------|----|------------------|
| 1 | Door | 6 | SureVend™ Sensor |
| 2 | Display Screen | 7 | Drip Tray |
| 3 | Drink Selection Menu | 8 | Adjustable Foot |
| 4 | Door Lock | 9 | Coin Entry |
| 5 | Cup Station | 10 | Cup Stand |
| | | 11 | Coin Return Cup |

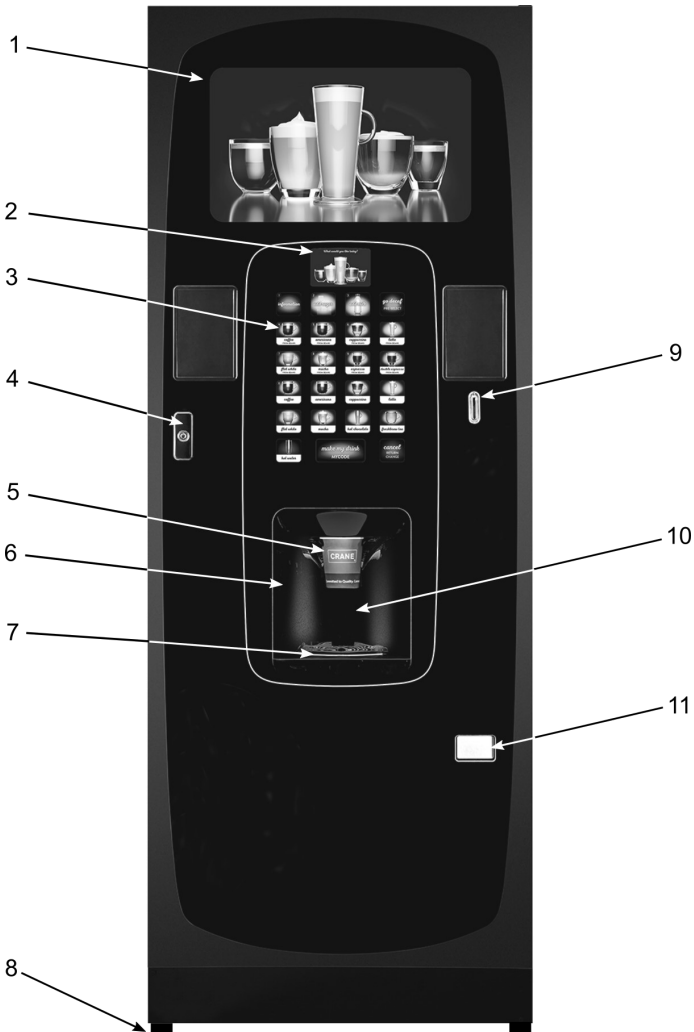

1.8 Internal Features - COTI / CALI

Key:

- | | | | |
|---|------------------------|----|------------------------|
| 1 | Main Switch | 10 | Kick Plate |
| 2 | Service Keypad | 11 | Waste Bucket (liquids) |
| 3 | Cup Turret | 12 | Waste Bucket (solids) |
| 4 | Cup Dispense Unit | 13 | Dispense Head |
| 5 | Door Locking Mechanism | 14 | Brewer |
| 6 | Cup Catcher | 15 | Mixer |
| 7 | Surevend™ Sensor | 16 | CoEx Brewer |
| 8 | Drip Tray | 17 | Ingredient Canisters |
| 9 | Drip Catcher | | |

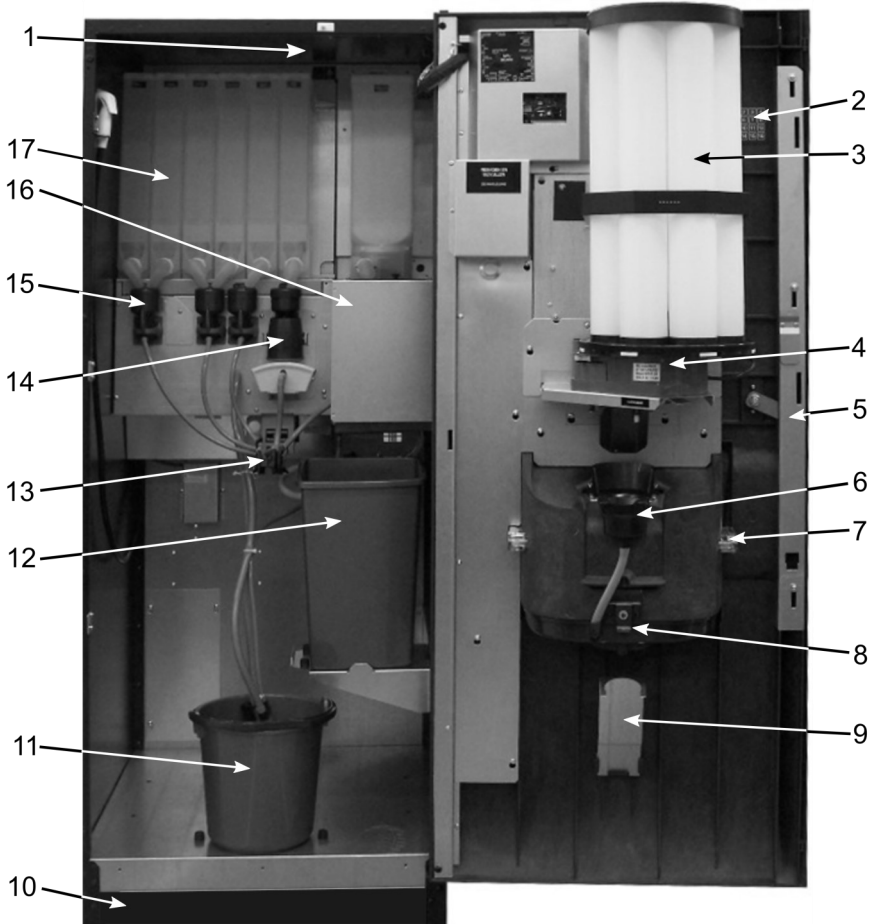

1.9 Internal Features - ICON

Key:

- | | | | |
|---|------------------------|----|------------------------|
| 1 | Main Switch | 10 | Kick Plate |
| 2 | Cup Turret | 11 | Waste Bucket (liquids) |
| 3 | Service Keypad | 12 | Waste Bucket (solids) |
| 4 | Cup Dispense Unit | 13 | Dispense Head |
| 5 | Door Locking Mechanism | 14 | Brewer |
| 6 | Cup Catcher | 15 | Mixer |
| 7 | Surevend™ Sensor | 16 | CoEx Brewer |
| 8 | Drip Tray | 17 | Ingredient Canisters |
| 9 | Drip Catcher | | |

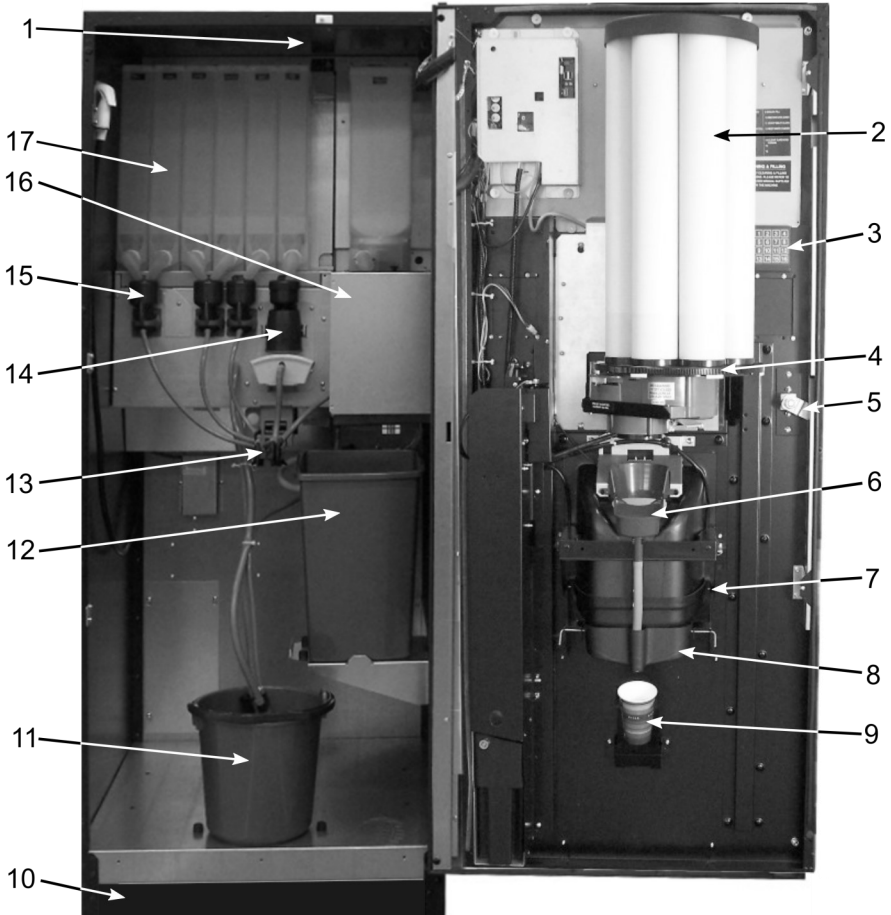

Section 2 - Installation



Important! It is essential that the personnel responsible for installing and servicing your machine, understand the following:

1. The installation and commissioning of your machine should only be carried out by a trained and authorised service technician.
2. All water and electrical services must be correctly and safely connected in compliance with national and local regulations.
3. All covers must be replaced correctly and securely and your machine left in a safe condition.

2.1 Siting your Machine

1. Your machine is only suitable for indoor use. We recommend that it be situated in an area with an ambient temperature not below 10° C and not exceeding 30° C. Your machine should be located near the appropriate water and electrical services, refer to Section 1.1 Specifications.
2. It must also not be sited in an area where a water jet could be used.
3. Prior to placing your machine in its final location, ensure that there is sufficient access space available via passageways, stairs, lifts, etc.
4. Ensure that access to the machine is restricted to personnel who have knowledge and practical experience of the appliance, in particular as far as safety and hygiene are concerned.

5. To ensure adequate ventilation, 100 - 150 mm (4 - 6 inches) clearance must be allowed between the back of the cabinet and the wall.
6. Open the door using the key provided. Remove transit packing and installation kit. Check for visual signs of damage which may have occurred during transit. If your machine is damaged or any parts are missing, you must contact the supplier immediately.
7. Level your machine in both the front-to-back and side-to-side planes by adjusting the feet. Ensure that the door opens and closes easily and the lock operates correctly.

2.2 Connecting the Water Supply

1. Your machine should be situated within 1 metre of a drinking water supply from a rising main, terminating with a W.R.C. approved 15mm compression stop-tap.

N.B. The water supply should comply with both local and national regulations.

Dynamic water pressure at the stop-tap must be within the limits 200 - 600 kPa (2 - 6Bar).

2. **Freshbrew & Espresso Machines:** COTI/CALI/ICON machines fitted with a Oltre freshbrew brewer or CoEx® brewer must be connected to the water supply via a water filter. This filter must be of food grade quality and able to remove temporary hardness (scale), heavy metals (lead, copper, iron, cadmium), chlorine and any organic pollutant's/discolouration.

 **Warning!** If your Freshbrew or Espresso machine is connected to a water supply and used without a water filter as specified above, your warranty will be void.

3. Connect the flexi-hose supplied with your machine to the stopcock. Flush the water supply before connecting the machine.

N.B. When connecting your machine to a water supply always use the new flexi-hose as supplied with the machine. Never re-use an existing hose.

4. Connect the hose to the inlet located on the rear of your machine. Ensure that the seal is correctly fitted. Ensure that all water supply fittings are tight.
5. Turn on the water supply at the stop tap and check for leaks.

2.3 Connecting the Electrical Supply

 **Safety First!**

The electrical safety of this appliance can only be guaranteed if it is correctly earthed. The manufacturer declines all liability for damage resulting from a system which has not been earthed. On no account should it be earthed only to the water supply pipe.

The appliance must be connected to a 200 - 230V 50/60Hz 13 amp fused switched socket outlet. Installed to the latest edition of the IEE regulations, using a 3 pin BS approved 13 amp fused plug for UK and in compliance with National and European regulations on electrical safety in other countries.

 **Important:** If any internal fuses become damaged or fail in any way they must be replaced by the correct fuse available from the manufacturer quoting the information written on the label adjacent to the relevant fuse-holder.

 **Important:** If the mains lead becomes damaged in any way it must be replaced by a lead available from the manufacturer.

2.4 Commissioning Procedure

A trained installation engineer must carry out the following procedure before the machine can be used for the first time. Ensure that the electrical and water services to the machine are connected correctly. Check for leaks in the water supply.

1. Open the front door of your machine.
2. Ensure that the waste bucket is fitted correctly. Clip the level probe and overflow pipes correctly onto the rim of the bucket.
3. **Cup Turret.** Unbox the cup tubes and lid and fit in place, then fill with the correct size cups for the cup catcher fitted to the machine. Allow the cups to drop into the tubes directly from the packaging. **DO NOT** touch the cups with your hands .

 **Important:** Do not fill the tube directly above the cup dispense position. Allow the cup turret motor to rotate a full tube to the cup dispense position. Rotating the cup turret by hand will damage the mechanism.

Note: If you are using paper cups, first inspect each sleeve for damage to the cup rims. Damaged cups must not be used.

4. The cup turret mechanism will index the first available cups to the dispense position and drop the cup stack into the cup drop mechanism. Fill the remaining empty cup stack with cups and replace the lid.
5. **All Models:** The water inlet valve will open and the heater tank will start to fill. As the water heats, ensure that no water overflows from the heater tank overflow pipe into the waste bucket. Check the system for leaks.
6. **Instant & Freshbrew Machines:** As heater tank fills and heats, ensure that no water overflows from overflow pipe into the waste tray.
7. **Espresso Models:** The machine will pump approximately 400ml of water through the system which will be heated to operating temperature.

Note: The machine has a safety cut-out which will only allow the heater tank to fill for a maximum of two minutes. If after software power-up the heater tank has not filled within this time, the mains power supply should be switched off and then on again to reset the heater tank time-out.



Important: Should the machine fail to fill correctly or leak, turn off the stopcock and the power to the machine before investigating the fault.

8. Check the display on the front of the machine to ensure that the water has heated to the correct temperature and that the machine is in standby mode.
9. **All Models:** Rotate soluble/freshbrew ingredient canister outlets to upright position. The bean canister needs to have the outlet slide in the closed position before removal.

10. Remove the canister from the machine and remove the lid. Place the canister into the canister filling station inside the cabinet on the left hand side, fill canister with correct ingredient.

DO NOT place the canister on the floor or overfill with ingredient.

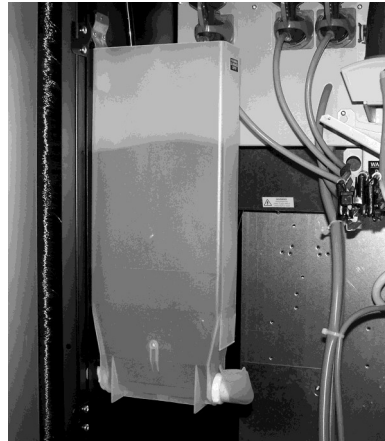

11. Carefully remove the canister from the filling station and replace the lid. Refit canister into machine ensuring that it is returned to the correct operating station.

Remember to open the canister outlet slide once the canister is in position.

12. Repeat this operation for all soluble/freshbrew ingredient canisters fitted to the machine. Rotate the canister outlets to their correct operating positions.

- 13. Ensure that the agitator is removed for any freeze dried products and the canister blanking bung is clicked into position.
- 14. **Espresso Models:** Close the outlet slide to seal the fresh beans canister outlet before removing the canister from the machine. Remove the canister lid. Hang the fresh beans canister on the rear of the door.

DO NOT place the canister on the floor.

Fill the canister with fresh coffee beans. Refit the canister lid and fit the canister into the machine, ensuring that it is located correctly. Open the outlet slide to ensure correct operation.

N.B. To maintain optimum drink quality, Crane Merchandising Systems recommend that the bean canister is replenished on a daily basis.

- 15. Press the Cup Test button (7), located in the Service Keypad on the rear of the door and ensure that a cup is ejected from the cup drop unit.

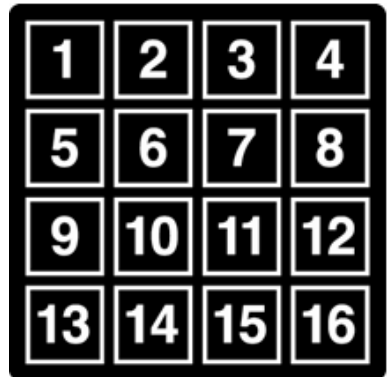

- 16. Press the Park Head button (8), located in the Service Keypad on the rear of the door and ensure that the dispense head moves to its fully extended position. Press the button again to return it to its correct (homed) position.

17. **Freshbrew Models:** Ensure the brewer cover waste deflection chute and brewer waste container are fitted correctly. Slide the container into position directly under the brewer with its lip outside the brewer cover.

18. All fitted monetary systems should be checked, note reader and cashless devices etc..

19. On Espresso models carry out a full CoEx clean using button 11 on the service keypad.



20. Operate the machine through its complete range of selections to ensure that each vend is correctly dispensed. Follow the instructions detailed in Service Keypad Functions for making a vend using the Test Vend button (6).

21. Close the cabinet door. Ensure that the machine is left in a clean and safe condition.

2.5 Setting Up the Carbonator Unit (Where Fitted)

1. Open the cabinet door. Fit the seal (1), provided in the installation kit, to the regulator as shown in the photograph. Connect the regulator to the CO₂ bottle.
2. Tighten the locknut. Carefully lift the CO₂ bottle into the machine ensuring that the gas supply pipe is not trapped or obstructed in any way.

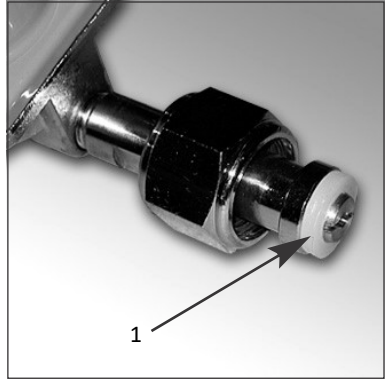

Safety First! The CO₂ bottle may be heavy. Always follow the correct procedure when lifting heavy objects.

3. Secure the CO₂ bottle with the safety chain. Turn on the supply from the bottle and ensure that the regulator (2) is indicating a pressure of 35 PSI.



4. Place the carbonator overflow pipe into the waste bucket. Fill the carbonator water bath with clean cold water until it starts to flow from the overflow pipe.

5. Switch on the carbonator unit using the Cold Unit switch located near the power supply.
6. Place the syrup containers in the bottom right-hand side of the cabinet and insert the dip tubes into the containers ensuring that the correct flavours correspond to the drinks displayed on the display.
7. Prime the syrup selections ready for use by pressing button 13 on the service keypad to display the following screen.



N.B. Ensure that the waste bucket is empty and in place before priming the pumps.

8. To prime syrup pump 1, touch and hold the Pump #1 icon until the syrup appears from the dispense head. Repeat for syrup pump 2 using the Pump #2 icon.

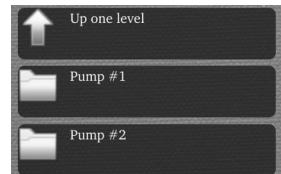

9. Touch the Up one level icon to return the machine to standby mode. Empty the waste bucket and refit to the machine.
10. Test vend the carbonated drinks to ensure correct operation of carbonator unit. Check for leaks and ensure that the machine is left in a clean and safe condition. Close the door.

N.B. If a still unit is fitted ensure that the ingredient timers for syrup drink 1 and 2 are set to 6 seconds (recommended).

2.6 Cup Drop Unit Set Up

Follow these instructions to correctly set up the cup drop unit to handle the cup size used.

1. Using a T20 driver loosen locking screw (A) and rotate green locking lever (B) clockwise.

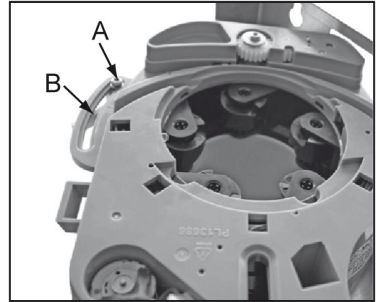

2. Slide the locking lever (C) until the scrolls are in their widest position.

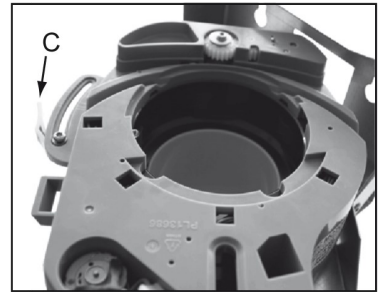

3. Select the correct step on setting ring (D) and using the locking lever, close the scrolls until they firmly grip the setting tool. Rotate locking lever anti-clockwise and tighten locking screw ensuring lever does not move.

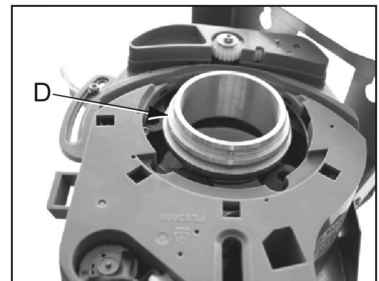

4. Remove setting ring, place cup in throat and (E) ensure that it is supported evenly on its rim.

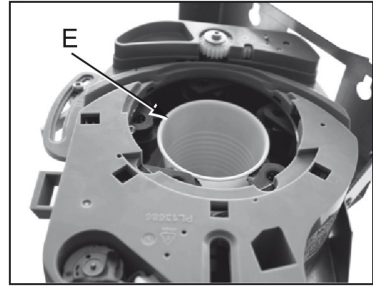

2.7 Stick Stirrer Adjustment (where fitted)

The Stick Stirrer dispenser is attached to the door with the stirrers stacked vertically and a chute to dispense the stirrers into the cup. The dispenser is adjustable to cater for different sizes of stirrer.

1. The guide (1) is adjustable and has three possible positions.
 - 90 mm
 - 105 mm
 - 115 mm (guide removed).



2. Remove the three screws (2) and move the guide to the required position to suit the size of stirrer used.
3. Replace the screws and load the stirrers from the top.
4. Ensure the stirrers are stacked flat to enable them to be dispensed correctly.
5. Place the metal weight back on top of the stirrers.

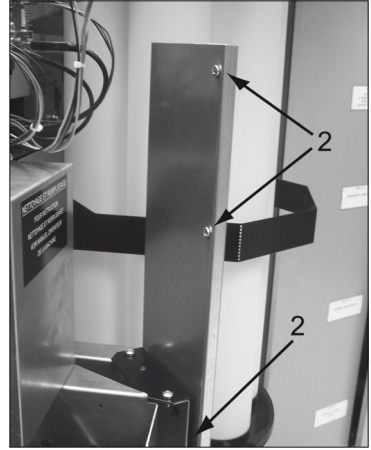

2.8 Warranty Card

Please complete and return the warranty card that comes with the machine. Use the card to note any problems you encountered during installation, your feedback helps us to improve our products and services. Return the warranty card, whether problems were encountered or not, **failure to do so may invalidate your warranty.**

Section 3 - Navigation and Programming Mode

3.1 Navigation - COTI

The COTI machine has a touchscreen where you Touch the icon of the option you require. For example:

To select the **Test** menu;

Touch the Test icon.

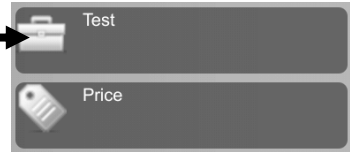

To disable an option or function;

Touch the Disabled radio button.



To enter numeric codes this screen is displayed.

Touch the numbers to enter the code and then **Touch Accept.**

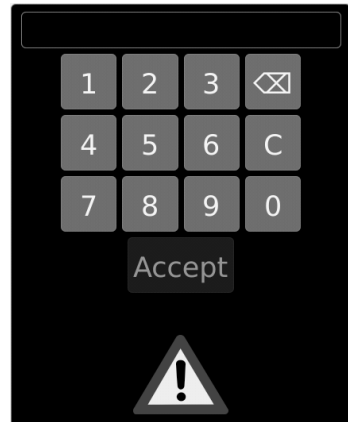

3.2 Navigation - CALI / ICON

The CALI / ICON machine has a capacitive sensing keypad beneath the drink selection buttons. These are used to select the drink of your choice or to navigate the program menus in service mode.

Display screen

Drink Selection Menu

Users Touch the drink selection of their choice to make a drink.

In the Programming mode these buttons are used to select the required menu option.

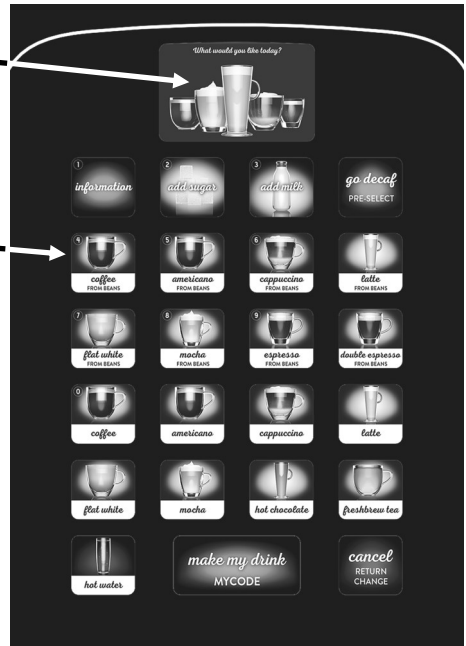

Depending on which options are available on the Programming Menu the corresponding buttons illuminate on the Drink Selection Menu. The buttons that do not have corresponding options on the Programming Menu are not illuminated.

Touch the illuminated icon that corresponds with the required option on the Programming Menu.

To enter the service menu this screen is displayed.

Decals in the Drink Selection menu have a number in the top left corner. Enter the correct PIN to access the Service Menu.

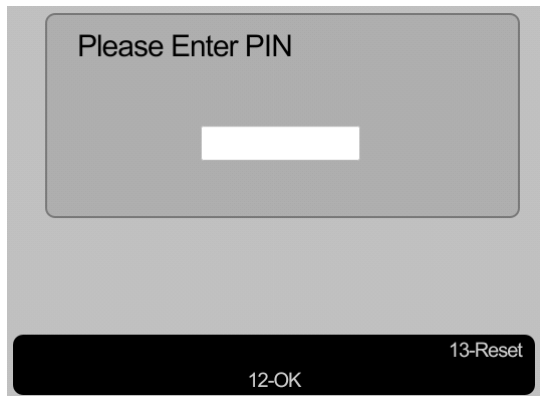

3.3 Program Entry

Programming mode utilises the interface seen below and enables the engineer to view and amend the service menus.

3.4 Navigating through the Menu Display

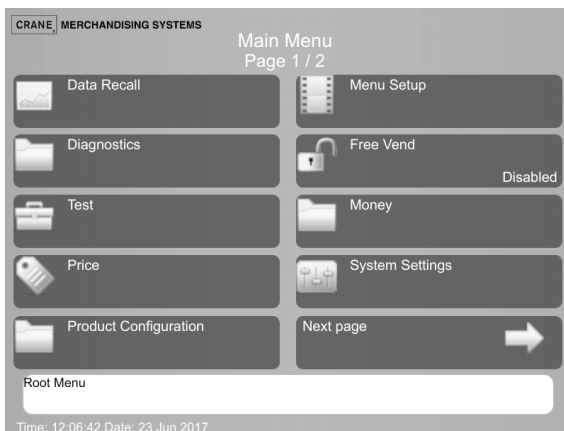

Both machines have full colour screens making navigation of the programming menu structure easy and intuitive.

1. There are two levels of programming mode and both are passcode protected:
 - **Operator** - this menu offers limited access to the software program, enabling drinks to be configured, data to be extracted and timed procedures and events to be programmed.
 - **Engineer** - this menu enables full access to the program to configure and run test procedures within the machine. This is detailed fully in Section 5.
2. Once access has been gained to the programming mode (refer to Section 3.5 Accessing the programming mode), the screen displays the programming Main Menu. Most subsequent menus follow the same format as this root menu.
3. The bottom of the screen, in the white panel, often displays important information concerning the item selected.
4. In certain configuration menus the current value is displayed against the item.
5. Navigation between multiple pages is via a **Next page** icon and to return to a higher menu via a **Up one level** icon.
6. Where a configuration parameter has been changed a **Save** icon maybe made available to save the setting and return to the previous screen.

3.5 Accessing the Programming Mode

To gain access to the programming mode:

1. Open the front door of the machine.
2. A Pin Entry screen is displayed (See Sections 3.1 & 3.2).
3. Enter in the four digit code PIN.to access the required programming mode.
4. Accept the entered PIN to enter the program, the Main Menu screen is displayed.
5. The factory default codes are:

COTI - Engineer’s 4444 and the Operator’s 3333.

CALI / ICON - Engineer’s 1111 and the Operator’s 2222.

These may be changed if required.

3.6 Entering or Updating Parameters

There are various forms of screens to change the configuration parameters of the machine, from Check Boxes, Radio Buttons to Value Increment and Value Entry.

3.6.1 Check boxes

These are used where there is a multiple selection of parameters available, in this example drink selections.

1. Select the required options and a tick appears in the check box. Select again to remove the tick.
2. When all the required options have been made select the **Up one Level** icon to return to the previous screen.



3.6.2 Radio Buttons

These are used to turn functions On/Off or to Enable/Disable them , where only one of a multiple of selections can be selected. In this example to name the soup that is available.

1. Select the required option, to fill the radio button.
2. When the required option has been made select the **Up one Level** icon to return to the previous screen.

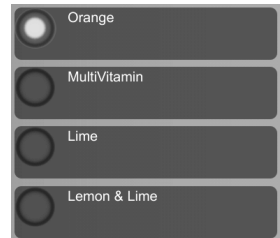

3.6.3 Value Increment

These screens enable a value to be increased or decreased, in this example setting the Heater Tank Temperature.

1. Use the— or + icons to increase or decrease the value as required.
2. Select **Save** to save and apply the new value.
3. Select **Previous page** to return to the previous page without saving any changes .

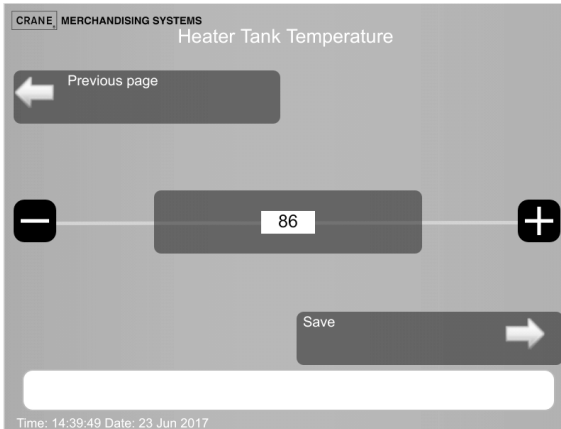

3.6.4 Value Entry

These screens enable a value to be entered, as a time (secs, mins) or a weight (grams).

1. Enter the required value and select **Save**.
2. **C** - clears any displayed value.
3. **Cancel**—exits the screen with no value.

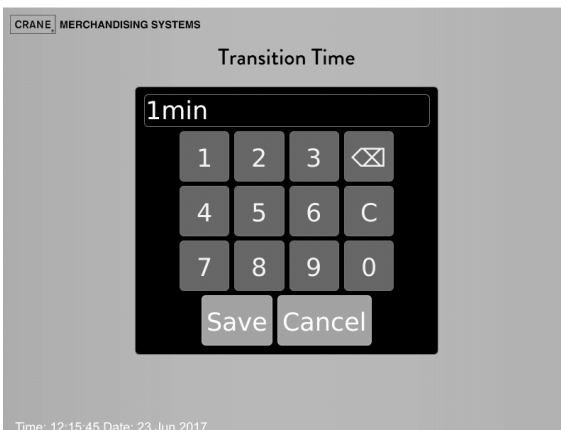

Section 4 - Customising the User Interface

This section explains how to add and change images and videos that are displayed on the interface; the background, product, stand-by and end-of-vend images, and information for the consumer (Sections 4.1 to 4.14).

The drink selections that are available to the consumer, the order the drinks appear on the screen, the prices and the language used can also be changed (Section 4.15).

To customise the User (Consumer) Interface:

- COTI machine - refer to Section 4.2.
- CALI / ICON machine - refer to Section 4.3.

4.1 Images

The following are the types of images, and areas where they are displayed, that can be used to customise the User Interface:

- Background - displayed while the drink is being prepared, refer to Section 4.6.
- Large Product - displayed while the drink is being prepared, if the drink requires Sugar and Milk choices the image is off-set to the left, refer to Section 4.6, if the drink doesn't require further choices the image is centred.
- Small Product - placed in the drink selection menu, refer to Section 4.6.
- Video – played while the drink is being prepared, refer to Section 4.6.
- Standby - enables a standby image to be displayed after the machine has remained idle for a set time, refer to Section 4.10.
- End of Vend - enables an image or video to be displayed when the vend has finished, refer to Section 4.6.
- Product name and description – appears alongside the product on the menu screen, refer to Section 4.8.
- Operator Manuals - enables the machine manuals to be viewed on screen, refer to Section 4.13.

The Background and Product images and Video can all be selected to appear against particular products i.e. if the user selects a Cappuccino they will see only images of a Cappuccino as their drink is prepared.

The images must be loaded onto a USB stick, inserted into the USB socket on the Atlas H Board (located on top left inside the door) and then copied onto the machine, where they can be selected for display, refer to Section 4.4.

4.2 Image Locations - COTI

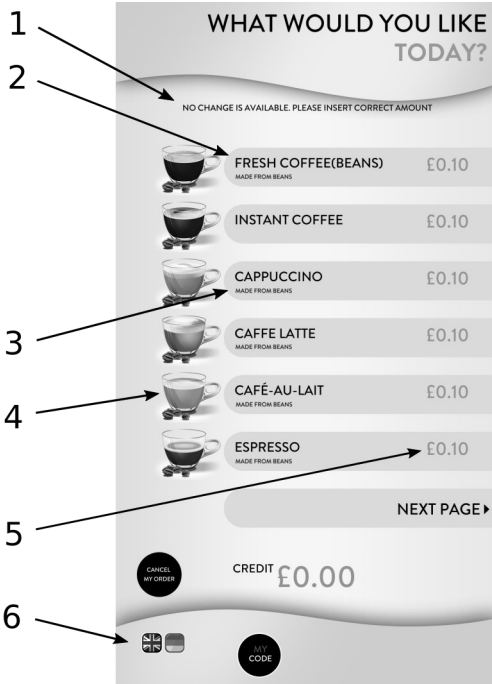

Key:

	Key:	Section
1	Machine Status Message	4.15.4
2	Product Name	4.8
3	Product Description	4.8
4	Small Image	4.6
5	Prices	4.15.6
6	Available Languages	4.15.2
7	Large Image	4.6
8	Allergens, Nutrition Info	4.10
9	Accepted Credit Card Types	4.10.6
10	Accepted Bills Display	4.10.7
11	Display Coin Set	4.13.3
12	Spinner	
13	Background Image	4.6
14	Animation, Video	4.6
15	End of Vend Image	4.10
16	Standby Image	4.10

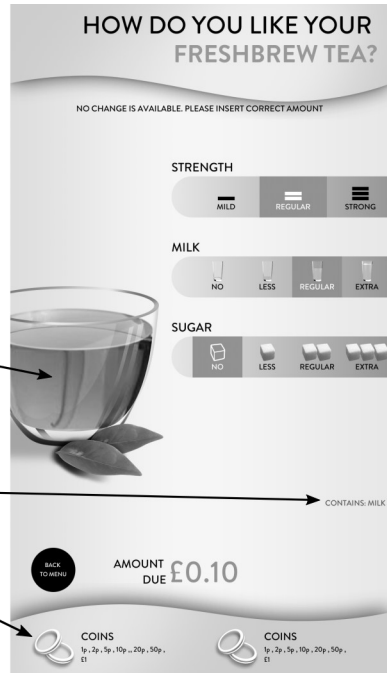

7, 10, 11

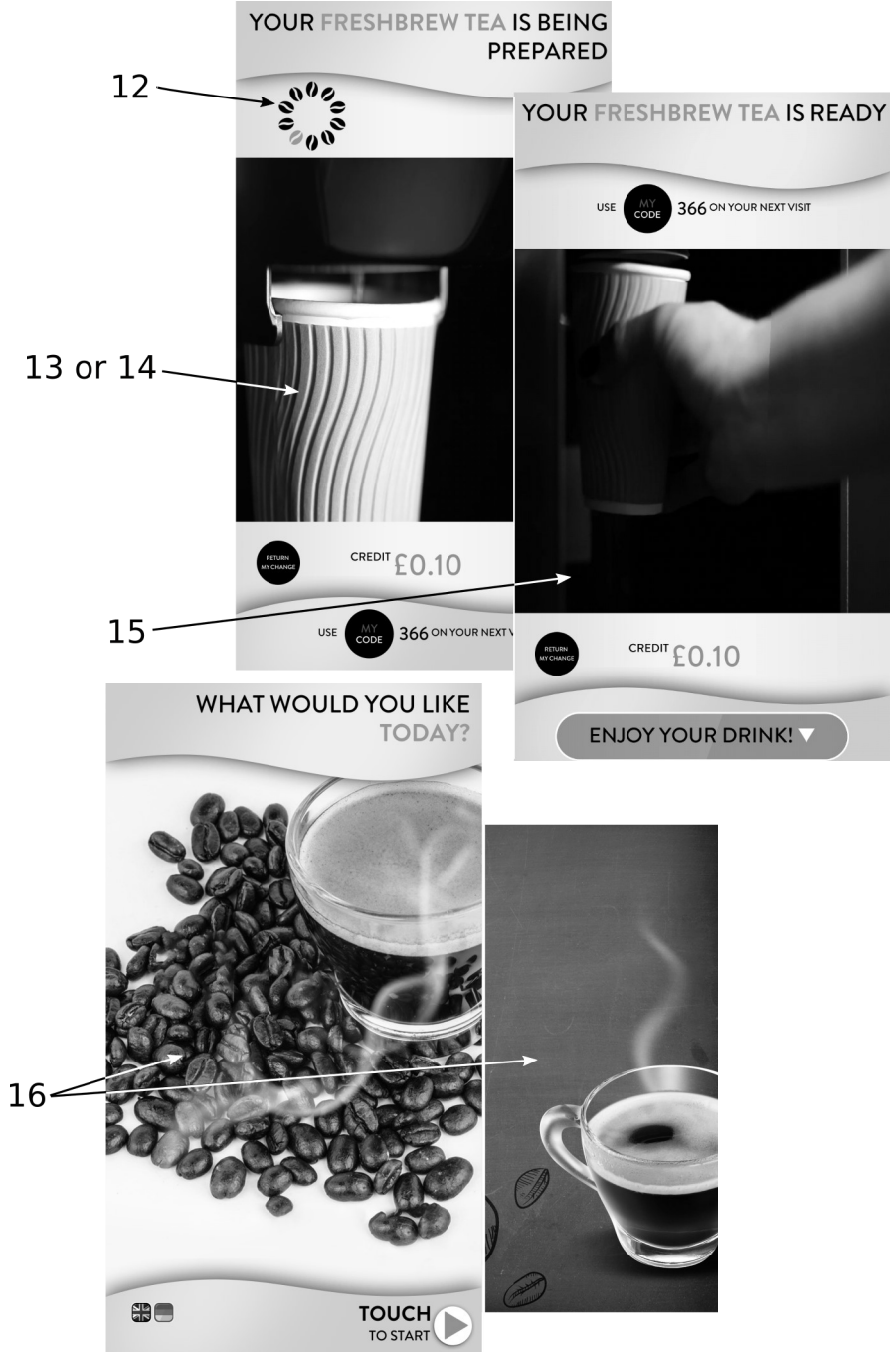

4.3 Image Locations - CALI / ICON

The Drink Selection Menu is a printed graphic which corresponds to the Machine Configuration and identifies the drink types available from the machine.

4.3.1 Drink Selection Menu

The printed menu graphics relate to the different model types available (Freshbrew or Espresso etc.).

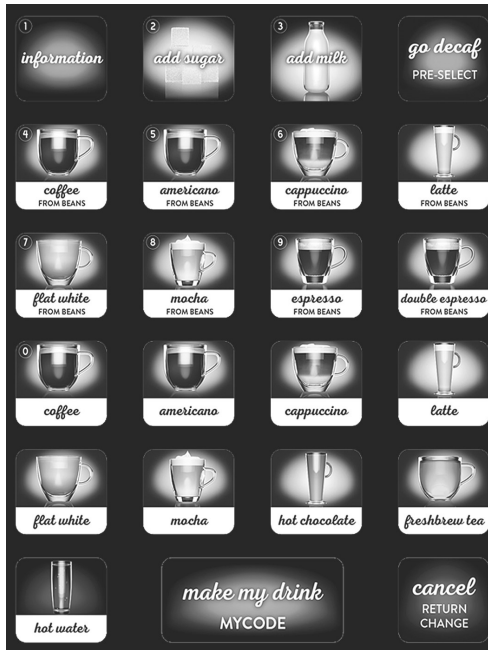

4.3.2 Display Screen

When selecting a drink the strength and milk and sugar levels can be adjusted. These are interactive with the selection menu and are shown on the screen accordingly.

An End of Vend video can also be displayed on this screen, refer to Section 4.6 for details.

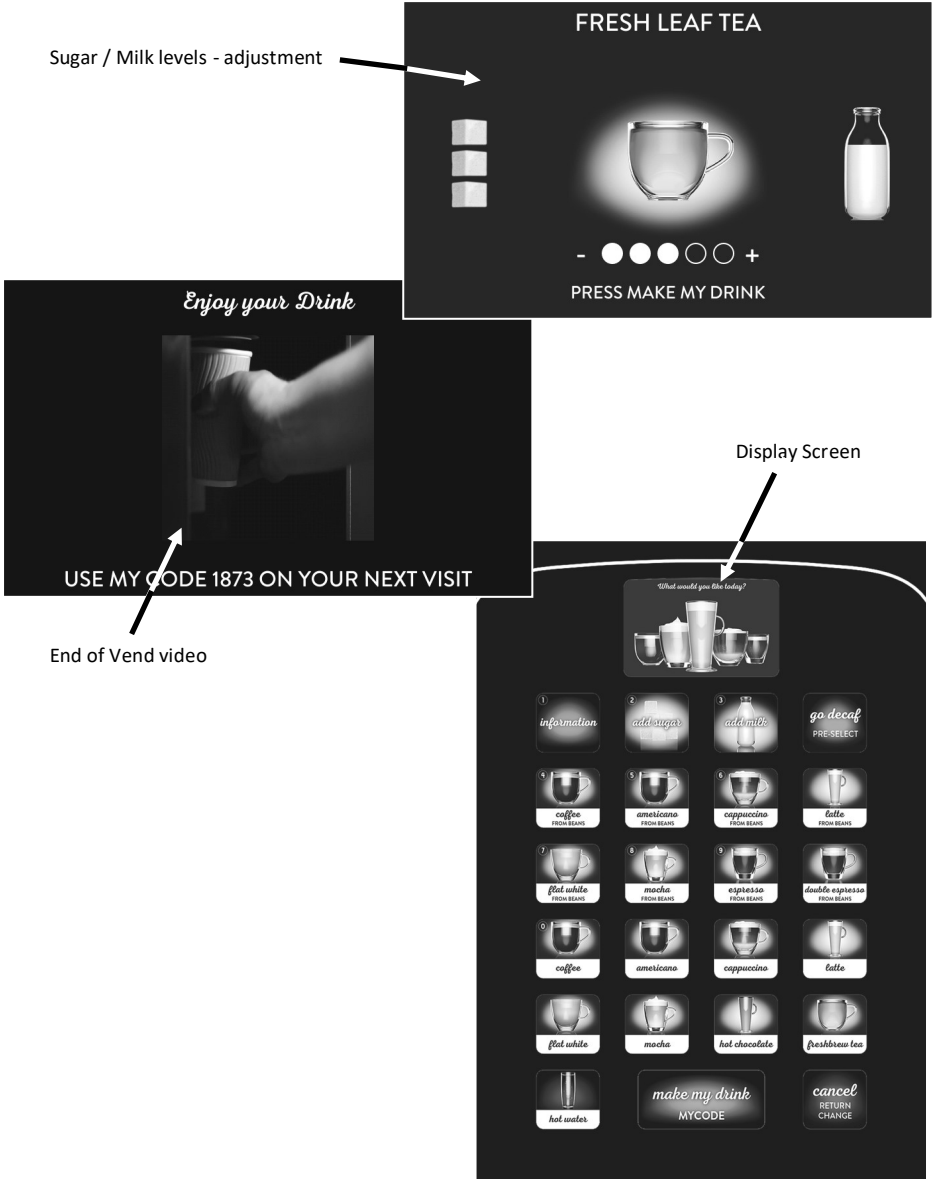

4.4 USB Stick Contents

The images saved on the USB stick must be a particular size, in the right format and be located in the right file path. These are detailed below:

4.4.1 COTI Machines

Image type	Size in pixels (W) (H)	File format	File path
Background icon	1080 x 1045	.png	atlas/product_library/background_pictures
Large icon	750 x 1006	.png	atlas/product_library/large_product_images
Small icon	190 x 162	.png	atlas/product_library/small_product_images
Video	1080 x 1045	.webm	atlas/product_library/video
Standby - Image	1080 x 1920	.png, .jpeg	atlas/screens
Standby - Video	1080 x 1045	.webm	atlas/screens
Operator Manuals	-	.html5	atlas/manuals

4.4.2 CALI / ICON Machines

Image type	Size in pixels (W) (H)	File format	File path
Video	800 x 310	.webm	atlas/product_library/video
Standby	800 x 480	.png, .jpeg, .webm	atlas/screens

4.5 Copy USB Stick Contents

The images on the USB stick can be viewed as follows:

1. On entry to the Engineer's Program the **Main Menu** is displayed.
2. Select **Product Configuration** and then **Copy content from USB stick** to display the following screen.

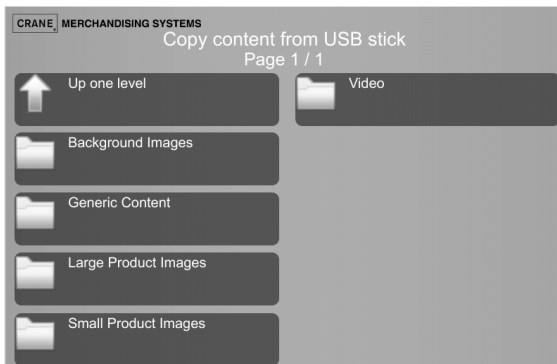

The following example shows how to copy **Large Product Images** from the USB stick onto the machine and select them for display on the User Interface.

N.B. The other image and video types are copied across and selected for use in the same way.

1. Select the required image type option to display the images available to be copied.
2. For this example select the **Large Product Images** option to display the following screen.

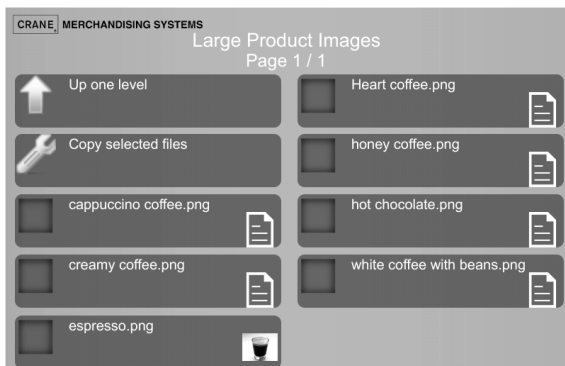

N.B. There may be further screens of images select **Next page** to display them and **Up one level** to return.

3. Select all of the images to be copied.

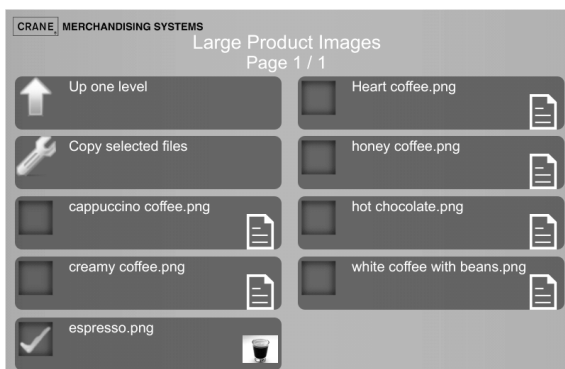

4. With all the required images selected, select **Copy selected files** option.
5. A **Copy selected files** confirmation screen is displayed.
6. Select **Yes** to continue.
7. Repeat the above procedure for each set of images or videos to be copied from the **Copy content from USB stick** screen.
8. On completion select the **Up one level** option to return to the **Product Configuration** screen.

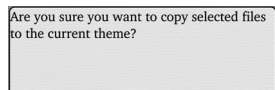

4.6 Select the Images for Display

To apply the images or videos to the User Interface from those stored on the machine:

1. From the **Main Menu** select **Product Configuration** and then **Change products information** to display the following screen.
2. This screen displays all the products that are available from the machine which may be displayed on more than one screen.

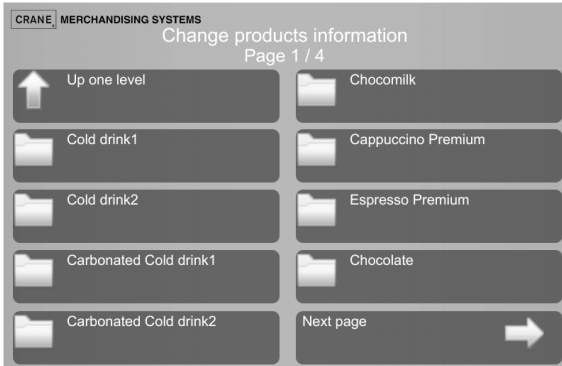

3. In the following example a **small_icon** is applied to the **Espresso Premium** option on the User Interface menu, the other options and images are selected in the same way.
4. From the **Change Product Information** (previous screen) select **Espresso Premium** to display the following screen.

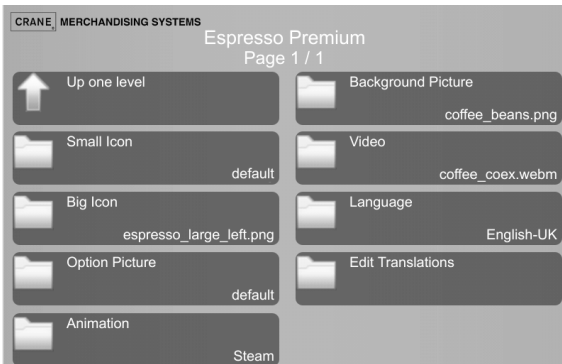

This screen displays all the image types that can be applied and are applied.

The applied image file name appears alongside each option.

6. To apply or change the image displayed against the selected product type select the image type, from the screen above.

- For this example select the **small_icon** option to display all the available small images that can be used on the drink selection (menu) screens.

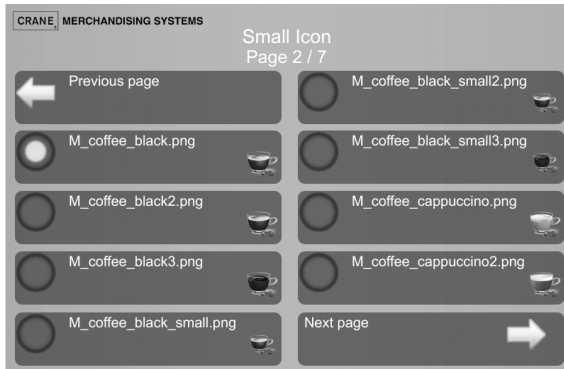

- Select **Next Page** to move through the **Small Icon** screens.
- Select the image that will appear against the **Espresso Premium** menu option.

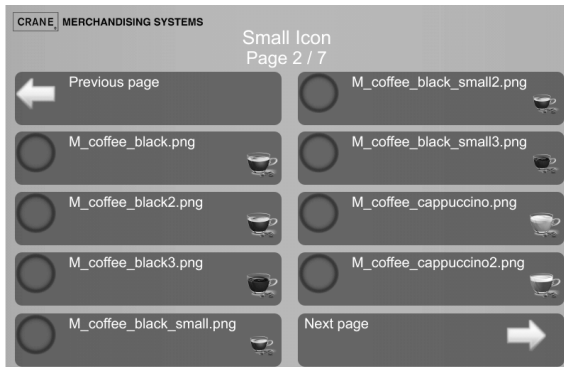

- Select **Previous page** to return to the **Espresso Premium** screen.
 - The selected image file name is displayed on the **Small Icon** option as on the screen below.
- This indicates that the image will appear against the **Espresso Premium** option on the Drink Selection screen.

12. Select the **Up one level** option to return to the **Change products information** screen, where another product can be selected and the required small image applied to the menu User Interface.
13. Repeat the above procedure for each product: selecting the **Product** on the **Change Products Information** screen, select the **Small Icon**, and image file.
14. To apply other images to the other image types:
 - Select the **Product**.
 - Select **Big Icon, Option Picture, Animation, Background Picture** or **Video**.
 - And repeat the above procedure.

4.7 Remove Content from Machine

This enables images on the User Interface to be removed. When changing displayed images they must first be removed using this screen.

1. From the **Main Menu** select **Product Configuration** and then **Remove content from machine** to display the following screen.

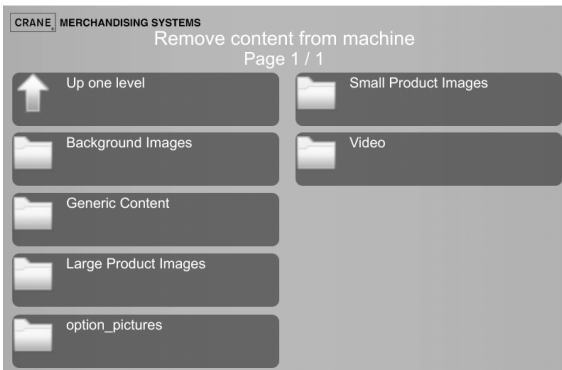

2. Select the image type option to display the images available.
3. For this example select **Large Product Images** option to display all available large images.

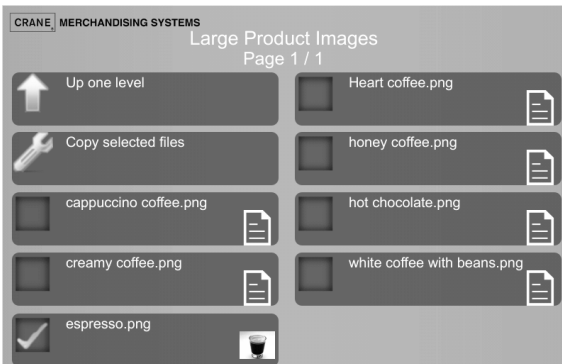

4. Select the images to be removed.
5. With all the required images selected, select **Remove Selected Files**.
6. On completion select **Up one level** to return to the **Product Configuration** screen.

4.8 Edit the Product Name and Description

This enables the product and product descriptions that appear on the User Interface selection Menu to be added or changed.

1. From the **Main Menu** select **Product Configuration** and then **Change products information** to display the previous screen.

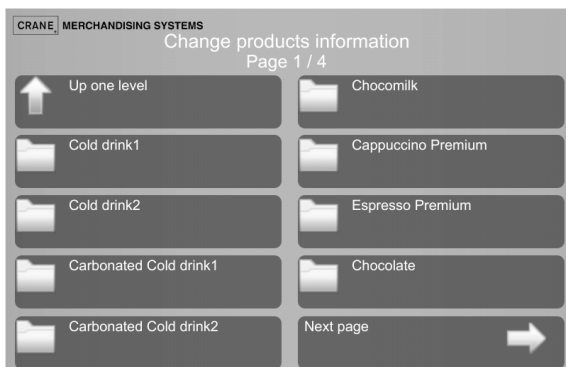

2. This screen displays all the products that are available from the machine which may be displayed on more than one screen.
3. Select the product (**Espresso Premium**) to be changed to display the following screen.

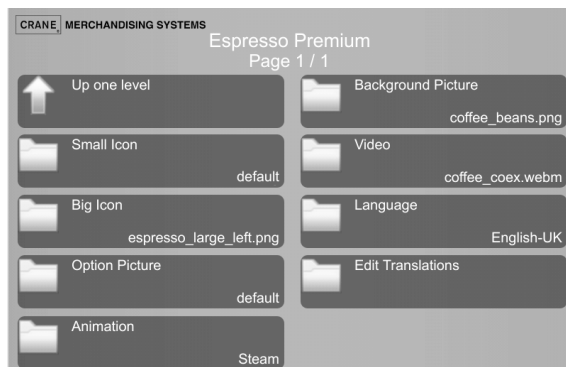

4. Select **Language** to display the available languages, select the required language and return to the above screen.

5. Select **Edit Translations** to display the following screen with three options:

- Option name
- Product name
- Product description

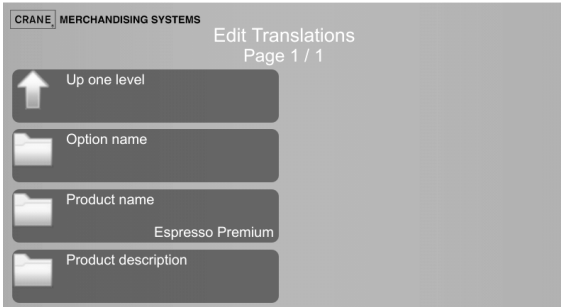

6. Select **Option name** to display a local language keyboard.

Type in the new name and select **Enter**.

The maximum no. of approximately 5 characters can be used.

The new name is displayed on the **Option name** option.

7. Select **Product name** to display a local language keyboard.

Type in the new name and select **Enter**.

The maximum no. of approximately 23 characters can be used.

The new name is displayed on the **Product name** option.

8. Select **Product description** to display the qwerty keyboard.

Type in the new description and select **Enter**.

The maximum no. of approximately 77 characters can be used.

The new description is displayed on the **Product description** option.

9. Select **Up one level** twice to return to the **Change products information** screen

10. Repeat the above procedure for each product name and description that requires changing.

4.9 Configure Generic Content

This enables an image or video to be displayed when the vend is complete. To configure and display the images on the User Interface is the same procedure as for other images, refer to Section 4.9 for details.

This image is displayed until the cup is removed from the cup station.

4.10 Standby Screen

This enables standby screens or videos to be displayed after the machine has remained idle for a set time. A set of different images can be selected that are displayed in turn on the User Interface.

This can be **Enabled** or **Disabled** and a **Transition Time** (or idle time) entered after which the Standby Screens are displayed.

From the **Main Menu** select **System Settings Page 3/3** and then **Standby Screen** to display the following screen.

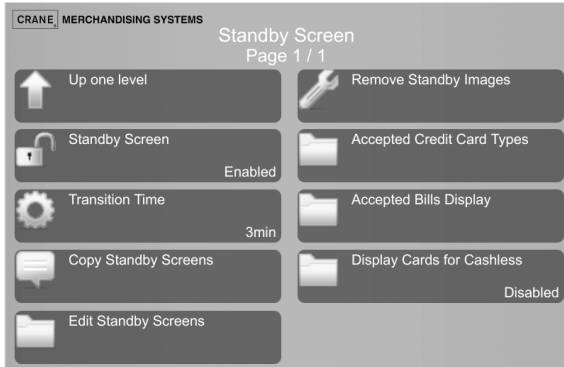

4.10.1 Standby Screen

This **Enables** or **Disables** this feature using the standard Enabled/Disabled options.

4.10.2 Transition Time

Select this option to enter a time in minutes that the machine can remain idle before the Standby Screen is displayed.

A numeric keypad is displayed tap in the time in the required minutes and **Save**.



4.10.3 Copy Standby Screens

To use the Standby Screens they must first be copied onto the machine.

1. Copy the required Standby Screen files onto a USB stick, refer to Section 4.5 for details of accepted file types, size and location.
2. Insert the USB stick into the USB socket on the Atlas H Board.
3. Select **Copy Standby Screens** on the **Standby Screen**.

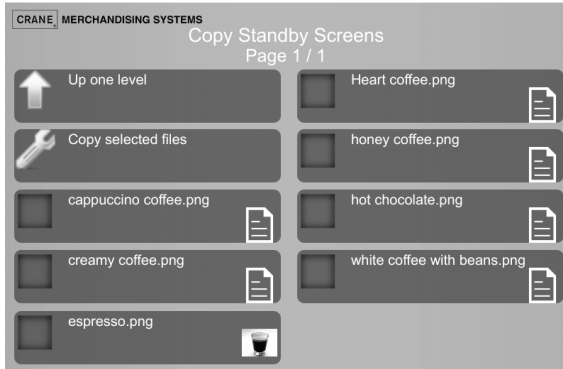

4. Select the required files to be copied and then select **Copy selected files**.
3. A **Copy confirmation** screen is displayed with the options **Yes** or **No**, select **Yes** to copy across the selected files.

4.10.4 Edit Standby Screens

This enables the selection of the images to be displayed when the machine is at **Standby**.

1. Select **Edit Standby Screens** to display the following screen.

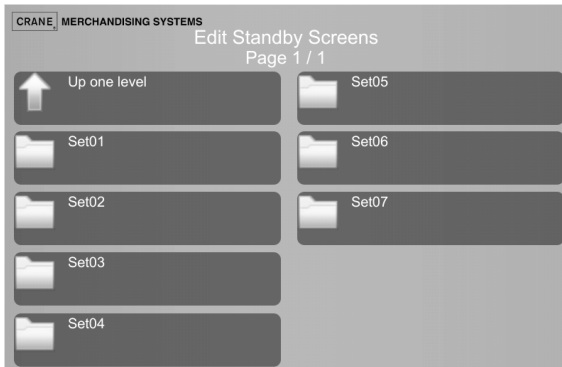

2. Each of the seven **Sets** on this screen is a place holder for a single **Standby Screen** image, all seven can be used or as many as are required.

3. Up to seven sets of images can be played when the machine is at idle, each screen is displayed for a set time or for its duration in the case of a video file, before the next. If only two images are used just these two will be displayed in turn.
4. Select a **Set** icon to display the following screen.

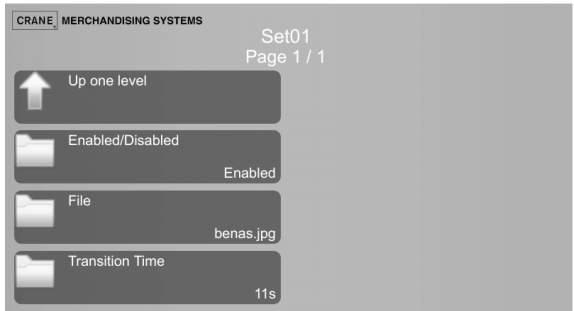

5. **Enable or Disable** this **Set**.
6. Select **File** to display the available **Standby** images on the following screen.

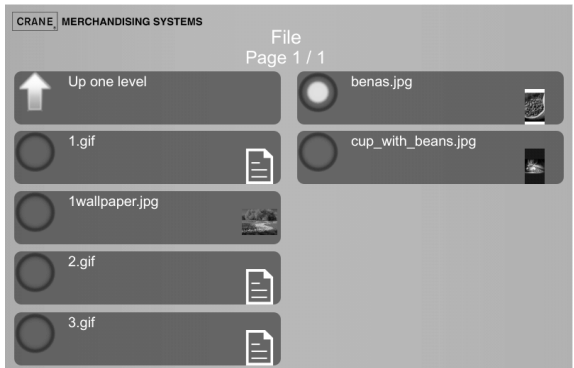

7. Select only one image and then **Up one level** to return to the **Edit Standby Screen**.
8. Repeat the above process for each **Set**, selecting one image per **Set**.
9. The **Transition Time** option enables a specific time a Standby image is displayed. A numeric keypad is displayed where a time in seconds can be entered.
10. The selected images will cycle round each time the machine returns to idle mode.
11. When all images are selected select **Up one level** to return to the **Standby Screen**.

4.10.5 Remove Standby Images

This enables images to be removed from the **Sets** and therefore from display.

1. Select **Remove Standby Screens** to display the following screen.
2. Select the image to be removed and then **Up one level** to return to the **Edit Standby Screen**.

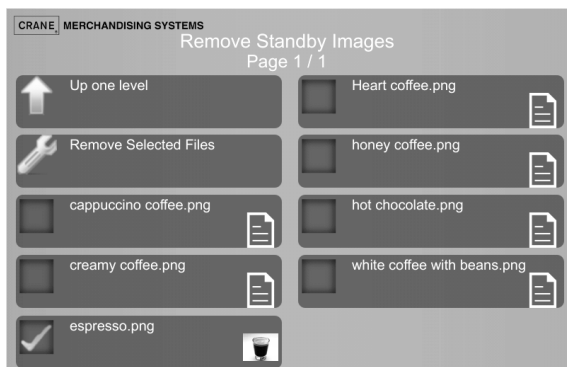

4.10.6 Accepted Credit Card Types

This feature enables images of **Credit Cards** to be selected for display. They are not necessarily the types of cards that can be used in the machine, just what is displayed.

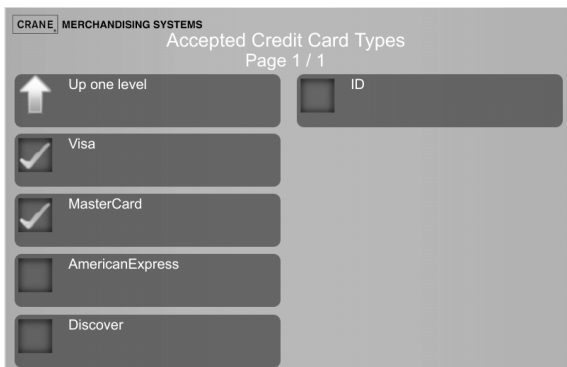

1. Select **Accepted Credit Card Types** to display the following screen.
2. Select the required **Credit Cards** and then **Up one level** to return to the **Standby Screen**.

4.10.7 Accepted Bills Display

This option enables the **Notes** that can be used to purchase a drink to be selected. The types that are selected are displayed on the User Interface for the consumer to see.

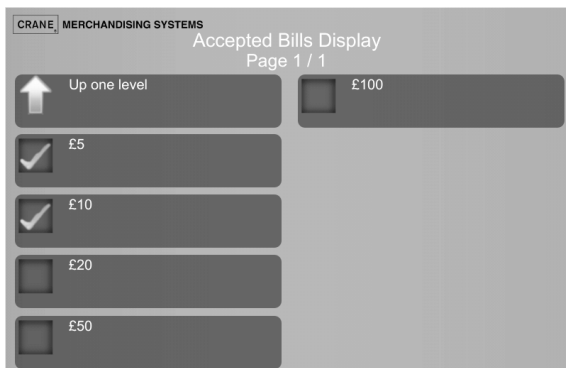

1. Select **Accepted Bills Display** to display the following screen.
2. Select the required **Notes** and then **Up one level** to return to the **Standby Screen**.

4.10.8 Display Cards for Cashless

This option enables images of the Card types to be displayed when the machine is in cashless mode.

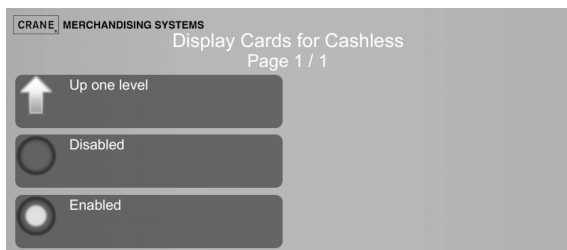

1. Select **Enabled** to display images of acceptable credit cards as selected in Para **4.9.6 Accepted Credit Card Types**.
2. Select **Disabled** to disable this option and remove images of acceptable credit cards from the User Interface.

4.11 Allergens

This enables any allergens associated with the selected ingredient to be displayed on the User Interface when a drink containing the related ingredient is selected.

- From the **Main Menu** select **Product Configuration Page 4/4** and then **Allergens** to display the following screen.

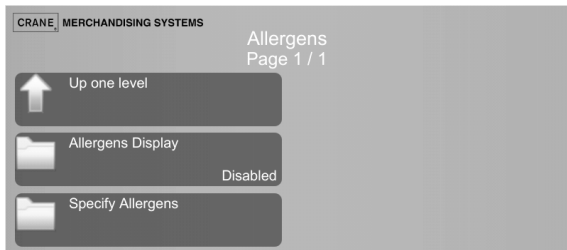

- Allergens Display** enables this feature to be **Enabled** or **Disabled**.
- Select **Specify Allergens** to display the following screen.
- This screen enables each ingredient used in the machine to be selected and any allergens associated with that ingredient.
- Select the ingredient to which the associated allergens are to be displayed from the following screens.

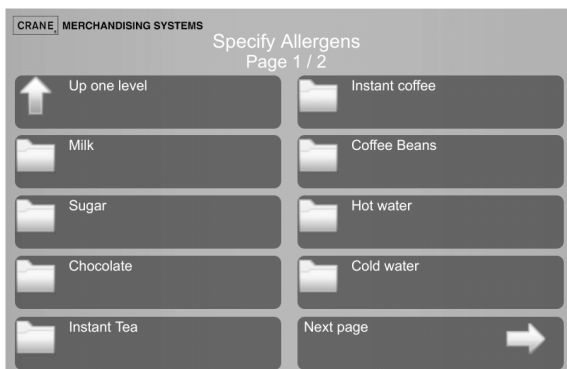

- For this example select **Milk**.

7. Select the allergens associated with the selected ingredient, **Milk**.

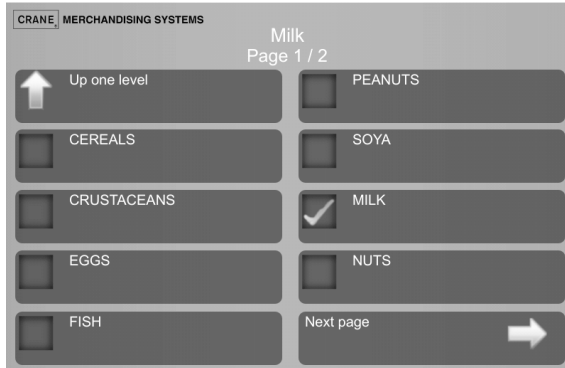

8. When complete touch the **Up one level** to return to the **Specify Allergens** to select the next ingredient.
9. With all ingredient and allergens selected touch the **Up one level** icon to return out of the **Allergen** screens.
10. If this feature is enabled each time a drink is selected with an ingredient that has associated allergens these will be displayed for the consumer to see.

4.12 Nutrition Info

This enables the nutrition information associated with the selected drink to be displayed on the User Interface.

1. From the **Main Menu** select **Product Configuration Page 1/4** and then **Nutrition Info** to display the following screen.

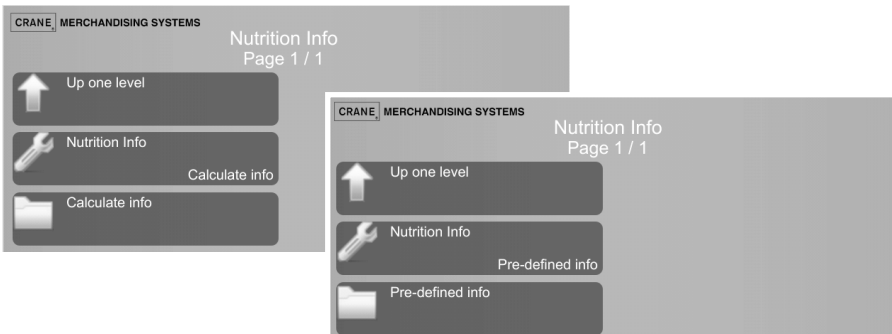

2. Select **Nutrition Info** to Enable / Disable this feature and to change between two ways to enter the nutritional value of the selected drink:

- **Calculate Info**

This enables the nutritional value of each ingredient in the machine to be entered and is used to calculate the overall value of that drink.

For example if you select:

A white coffee, the ingredients are milk and the coffee,

A white coffee + medium sugar, the ingredients are milk, coffee and sugar.

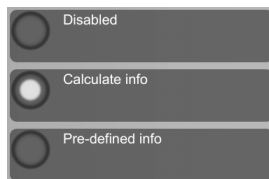

- **Pre-defined Info**

This enables a pre-defined value (not a calculated value) for each drink to be entered.

4.12.1 Calculate Info

To use this feature **Ingredient Set-up** must have been used to calibrate the amount of product that is dispensed pre vend, see Section 5.7.1 for details. The Nutritional values of each ingredient must also be known, these are normally found on the ingredient packaging.

1. Select **Calculate Info** on the **Nutrition Info** screen, to display a screen of all the ingredients in the machine.
2. Each ingredient must be selected in turn and the nutrition values entered against each.
3. For example select **Milk**, to display the following screen.

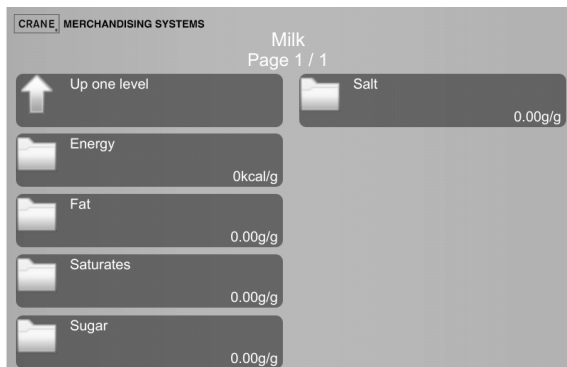

4. Using the values found on the ingredient packaging enter these against the options on this screen.
5. A numeric keypad is displayed for the value entry.
6. Enter these values for each ingredient.

4.12.2 Pre-defined Info

To use this feature **Ingredient Set-up** need not be set up, see Section 5.7.1 for details. The Nutritional values of each ingredient must also be known, these are normally found on the ingredient packaging.

1. Select **Pre-defined Info** on the **Nutrition Info** screen, to display a screen of all the drinks available from the machine.
2. Select each drink in turn to add the nutrition values entered against each.
3. For example select **Coffee**, to display the following screen.

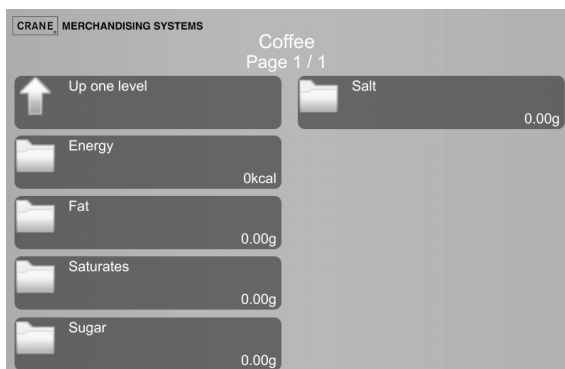

4. Using the values found on the ingredient packaging enter these against the options on this screen.
5. A numeric keypad is displayed for the value entry.
6. Enter these values for each drink .

4.13 Operator Manuals

This feature enables the machine Manuals to be loaded onto the machine and viewed by the engineer on the screen.

From the **Main Menu** select **System Settings Page 1/3** and then **Operator Manuals** to display the following screen.

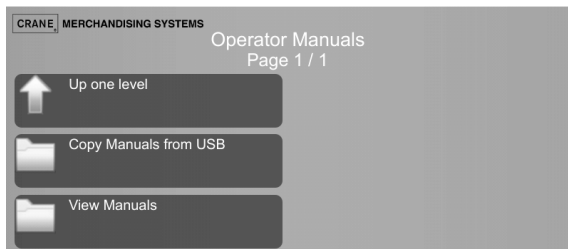

4.13.1 Copy Manuals from USB

This enables the machine manuals to be loaded onto the machine and then viewed on the screen.

4.13.2 View Manuals

Selecting this option displays the manuals available on the machine and enables selection of the required manual, displaying it on the screen.

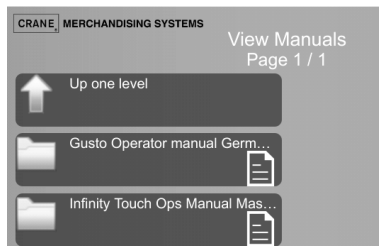

4.14 ADA Mode (COTI machine only)

This feature changes the workflow of the drink selection menu to meet ADA regulations and enable wheelchair users to easily navigate the drink selection menu.

A Wheelchair (Disabled) Symbol appears on the User Interface, using this button the drink selection menu scrolls up from the bottom of the screen.

4.15 Additional User Interface Options

The following are features that can also be used to customise the User Interface.

4.15.1 Menu Setup (COTI machine only)

This menu enables the position of the available drinks on the drink selection menu to be changed. A maximum of six drinks can be offered on one menu if more are offered further menus are displayed. Refer to Section 5.8 **Menu Setup** for more information.

4.15.2 Language

The machine can be set up to display the drink selection and any text to be displayed in a choice of languages, enabling the consumer to view the drinks in a language they can understand. The languages made available are displayed at the bottom of the User Interface as circular flag icons or as text of the relevant country. Refer to Section 5.11.6 for more information.

4.15.3 Currency Setup

This enables the currency used in the machine to be selected, refer to Section 5.10.2 for more information.

4.15.4 Low Change Message

When the value of coins in the machine falls below a certain value a **Low Change** message can be displayed. Refer to Section 5.10.10 for more information.

4.15.5 Custom Selection Names

This enables the drink names that appear on the drink selection to be changed, refer to Section 5.7.5 for more information.

4.15.6 Price

This enables the prices of the drinks to be changed, refer to Section 5.6 for more information.

4.15.7 Screen Brightness

This enables the brightness of the drink selection screen to be adjusted, refer to Section 5.11.8 for more information.

Section 5 - Engineer's Program

The Engineer's Program enables the machine to be configured, and sales and diagnostic information viewed. The machine is supplied with default configurations for minimum setup time, however some setup is required and certain settings can be adjusted for specific consumers and their preferences. To access this program, navigate, select and enter values refer to Section 3 – Programming Mode for detailed information.

The menu structure is laid out below with brief explanations for each screen, with references to more detailed information and tasks.

5.1 Menu Structure Overview

Main Menu Page 1/2 (Section 5.2)

Data Recall (Section 5.3)	enables monetary and sales data to be viewed
Non Resettable Sales Data	the accumulative data values for the life of the machine
Resettable Sales Data	enables data to be viewed and cleared, enabling data to be recorded over a period of time
Events	enables certain events which have happened with the machine to be viewed: power losses, last actions etc..
Identification Numbers	this displays the serial numbers of any the boards and MDB equipment fitted
SureVend™	displays details of SureVend™ activities
Mug Vends	displays a count of Mug vends
Cup Vends	displays a count of Cup vends
Diagnostics (Section 5.4)	this displays any errors that have occurred: active and historic with the ability to clear
Test Page 1/2 (Section 5.5)	enables operations and components to be tested
Switches & Sensors	displays the current state of all switches and sensors in the machine
Components	enables individual or collective components to be test
Keypad	enables the touch-keys on the drink selection interface and the buttons on the service keypad to be tested
Coin Return Motor	runs the motor
Display	illuminates the screen and touch-key lights
Door Lights	runs a sequence of tests on the door illuminations
Dispense Head	ensures that the dispense head can move to the selected position

Vend Without Cup	enables drinks to be delivered without a cup being dispensed from the machine
Test Page 2/2 (Section 5.5.9)	
Vend With Cup	enables drinks to be delivered into a cup dispensed from the machine
Cup Drop	drops a cup
CoEx Module	tests the CoEx module components
Stick Stirrer	enables a stirrer to be dispensed with dry sugar
Water Tank Module	purge the water filter
Price (Section 5.6)	enables the pricing of drinks
Individual Prices	enables the price of all the individual drinks to be changed
Category Prices	enables prices to be set for categories of drinks
Entire Machine	set one price for all drinks
Mug Discount	set a discount for consumers using their own mugs
High/Low Price	displays the price range
Product Configuration Page 1/4 (Section 5.7)	enables all aspects of the drinks to be setup and adjusted.
Ingredient Setup	a method of weighing ingredient to calculate grams per second, to support back office management systems
Nutrition Setup	Enables drink nutritional information to be calculated and displayed
Copy content from USB stick	copy User Interface images onto the machine
Remove content from machine	enables images on the machine to be deleted
Change Products Information	enables the product name and description on the drink selection screen to be changed.
Change Group Information	enables group information to be changed
Configure Generic Content	enables an End of Vend image or video to be added
Heater Tank Setup	enables the target water temperature, the minimum temperature for a drink and displays the current tank temperature

Product Configuration Page 2/4 (Section 5.7.6)

Selection Timers	enables the recipes of each drink to be adjusted
Custom Selection Names	enables a name to be selected for Still Syrup pump and Soup drinks
Jug Vend Configuration	enables the selection of drinks available, the number of cup vends per jug and to enable/disable SureVend™
Water Compensation	adjust dispensed water quantity from CoEx drinks
Disable Selections	enables individual selections to be disabled
Token Enabled	enables which drinks are available with payment by token
SureVend™	enable or disable SureVend™
Cup Mechanism	can be switched off if mug vend only is used

Product Configuration Page 3/4 (Section 5.7.12)

Cup Sizes	enables the cup size used in the machine to be selected
Brewer Waste Management	enable or disable and to manage brewer waste capacity
Water Filter Management	enable or disable and to manage filter service intervals
Bowl Rinse	rinses the bowl with the dispense head in the home (back) position
CoEx Brewer	set the CoEx cleaning routine, CoEx module type and pre-vend heating routine
Oltre Brewer	enables the brewer configurations to be viewed and set-up
Water Only – No Cup	enables hot and cold water to be dispensed without a cup being dispensed
Stick Stirrer Settings	enables the configuration of the stick stirrer

Product Configuration Page 4/4 (Section 5.7.20)

Low Water Reset	controls the boiler fill process
Allergens	enables the display of any allergens in the selected drink
Menu Setup (Section 5.8)	enables the drink selection menu layout to be changed
Free Vend (Section 5.9)	removes all pricing from the drink selection menu
Money (Section 5.10)	controls all aspects of payment from currency to payment methods and change. The options available depend on the equipment fitted

System Settings Page 1/3
(Section 5.11)

Operator Manuals	enables manuals to be viewed on the screen
ADA Mode	enables the drinks selection to be configured for disabled users
Machine Information	enables machine info to be recorded and displayed on the screen if the machine becomes inoperable
Machine Id	enables the machine's Id to be changed
Machine Configuration Id	displays the current configuration and enables selection
Time and Date	enables the time and date to be set
Language	enables individual languages to be set for both the engineer and user
DTS	Data Transfer Standard, enables the method of data transfer from the machine to a device to be specified

System Settings Page 2/3 (Section 5.11.8)

Screen Brightness	enables the brightness of the screen in both standard and power save mode to be set
Update Advertisements	for future development
Software Updates	Enables updating of the Atlas board software
Backup/Restore	enables a backup of the current configuration to be made and restored
Clone Settings	enables the current configuration to be copied to, and restored from, a USB stick
Custom Configurations	pre-programmed configurations can be selected
Software Version	displays details of the version currently installed
Temperature Units	enables the selection of Celsius or Fahrenheit

System Settings Page 3/3 (Section 5.11.16)

Keyless Transitions	enables Jug and Free vend via PIN codes
Standby Screen	enables the machine to display a standby screen and to set a time between the last vend and when the standby screen is displayed
Default Dispense Head Position	sets the position of the dispense head after a vend
Automatic Reboot Settings	enables the time of reboots to be changed

Buzzer Settings	changes the sound behind the touch screen.
Debug Log Enable	enables the capture of log files for fault analysis
LED Device Type	enables the selection of a LED colour scheme

Main Menu Page 2/2

Security Codes (Section 5.12)	enables access to the machine to be restricted, codes for Engineer & Operator access, & Jug & Free Vend
Timed Events (Section 5.13)	enables the setup of procedures that the machine automatically carries out.
Telemetry (Section 5.14)	for future development
Leave Service Application (Section 5.15)	exits the Engineer's Program and returns the machine to standby mode
Machine Reboot (Section 5.16)	enables the machine to be rebooted

5.2 Main Menu

This is the top level menu in the engineering program and enables access to all programming / configuration sub menus.

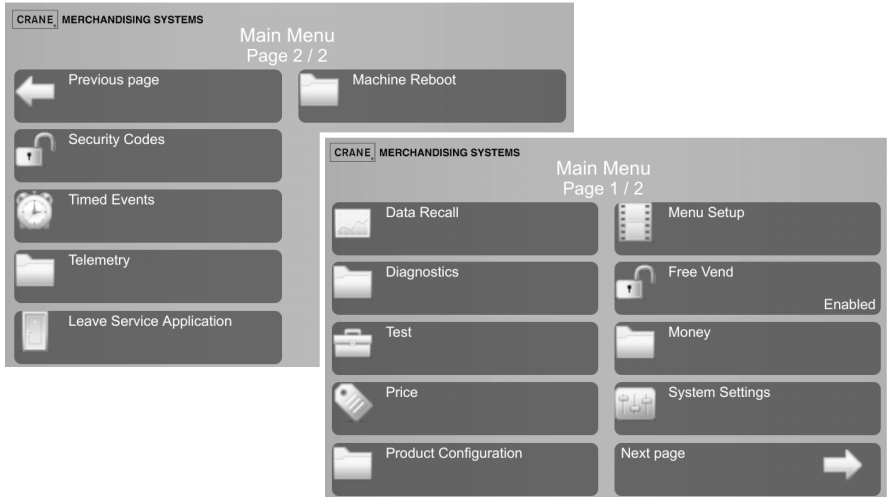

5.3 Data Recall

This menu enables the engineer to view Non-Resettable and Resettable Sales Data, view data relating to Events and SureVend™ assisted vend information. The Re-settable Sales Data and SureVend™ data menus contain an extra sub-menu which enables the engineer to delete the re-settable data from the machines memory.

N.B. All sales data is presented in a format required by the latest European Vending Association Data Transfer Standards (EVA DTS). Surcharge data fields are not supported by this machine.

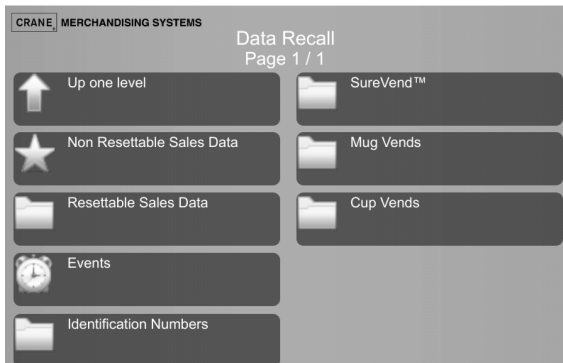

5.3.1 Non Resettable Sales Data

This menu enables the engineer to view and record monetary and sales values. This data cannot be reset and will remain intact for the service life of the control board (or the back-up battery is removed).

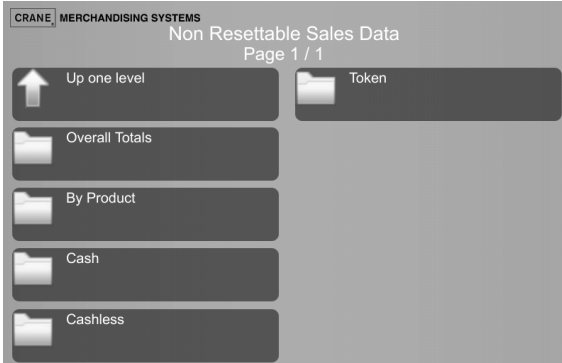

Data is displayed in the following options:

5.3.1.1 Overall Totals

1. This displays the total sales in a table listed under: **Sales, Discounts, Test Vend, Surcharge, and Free Vend.**
2. The currency column indicates the total monetary value and the # column indicates the total number of actual vends for each data type.

5.3.1.2 By Products

1. This enables the total machine sales for each product to be displayed in a table under: **Price, Sales, Discounts, Test Vend, Surcharge, and Free Vend.**
2. The **Price** row indicates the price of the actual product.

5.3.1.3 Cash, Cashless and Token

1. These enable the total machine sales in **Cash, Cashless** and **Tokens** to be displayed.

5.3.2 Resettable Sales Data

This menu contains similar data to that available from the **Non Resettable Sales Data** menu. However, once viewed, data from this menu can be cleared from the machines memory and enables sales data to be recorded over a period of time.

The options **Clear Data** and **Reset** are available to reset the sales data, a warning is given before the data is reset.



5.3.3 Events

This screen enables certain events which have occurred in the machine to be viewed.

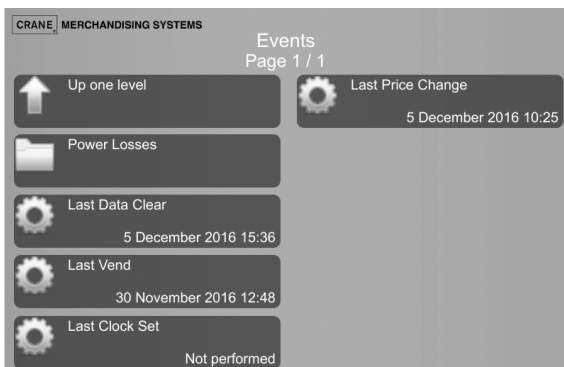

1. **Power Losses** displays a table listing the most recent occasions (10 maximum) when power to the machine was disconnected. Details of the **Date**, **Time** and **Duration** are displayed.
2. Details of when the **Last Data Clear**, **Last Vend**, **Last Clock Set** and the **Last Price Change** were performed are display directly on this screen.

5.3.4 Identification Numbers

This screen displays information about the MDB coin/card device if fitted to the machine. Information such as serial and part number and version types of the **Coin Mechanism**, **Bill Validator** and **Card Reader** are displayed directly on screen.

5.3.5 SureVend™

This screen displays details of SureVend™ activities.

1. The totals of **Cup Drop Failures** and **SV Assisted** vends are displayed directly on the screen.
2. An option to **Clear Data** is available to reset the totals, a warning is given before the data is reset.



5.3.6 Mug Vends

This screen displays the total number of vends the machine has made without dropping a cup.

1. An option to **Clear Data** is available to reset the total, a warning is given before the data is reset.

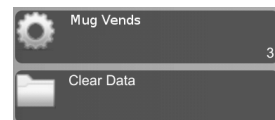

5.3.7 Cup Vends

This screen displays the total number of cup drop vends the machine has made.

1. An option to **Clear Data** is available to reset the total, a warning is given before the data is reset.

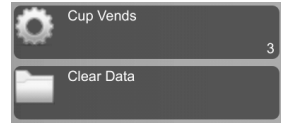

5.4 Diagnostic

Should a fault occur within the machine the error is logged and a message is displayed. In some cases this may cause the machine to be inoperable.

5.4.1 Active Errors

This details all the active errors, listing them in a table under the headings: a description of the error **Event** and the **Time** and **Date**, refer to Section 10.1 Diagnostics for a complete list of error messages.

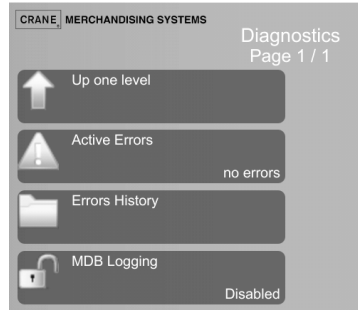

5.4.2 Errors History

This displays a table of all the active errors.

1. The total of the **Active Errors** is display on screen with the ability to view the fault details (**Event Id**, **Time** and **Date**) in a table.
2. A table of **Errors History** can also be viewed with the option to **Clear History** from the table, a warning is given before the data is reset.

NB. Refer to Section 10.1 Diagnostics for a complete list of error messages.

Description	Time	Date
Coin Tube 4 empty (1)	11:26:16	05 Dec 2016
Coin Tube 1 empty (1)	11:26:00	05 Dec 2016
Coin Tube 0 empty (1)	11:25:46	05 Dec 2016
Coin Tube 2 empty (1)	11:25:14	05 Dec 2016
Coin Tube 3 empty (1)	11:25:00	05 Dec 2016

5.4.3 MDB Logging

This option is for future development and is not currently available.

5.5 Test

This menu enables the engineer to test individual components and switch inputs to ensure correct operation.

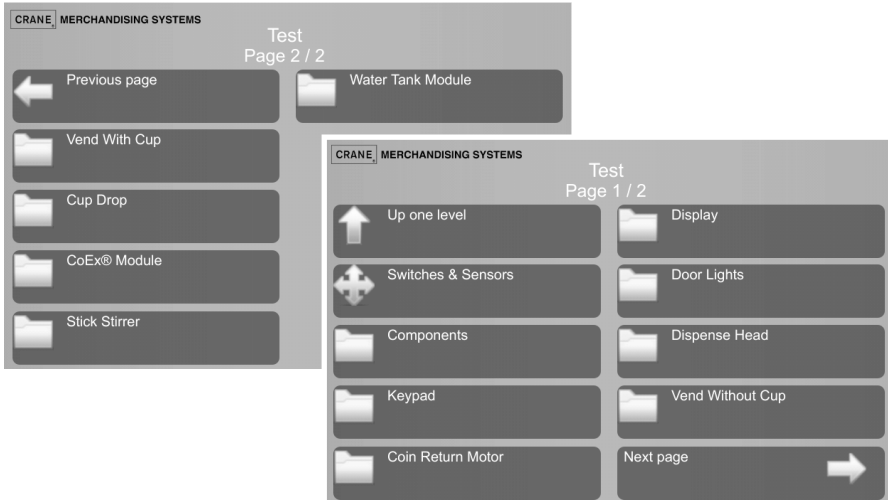

5.5.1 Switches & Sensors

This screen displays the current state of all switches and sensors, this is active information and can therefore change.

1. This information can be used to determine the status of each switch and sensor.

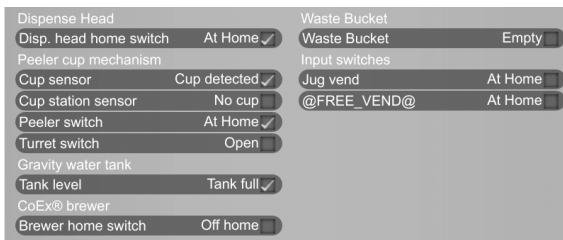

5.5.2 Components

This menu enables the engineer to test the operation of individual or collective valves and motors on the components displayed. While the tests are running the 'test animation' accompanied by a Test Started message. On a successful completion of the test the screen returns to the Components screen.

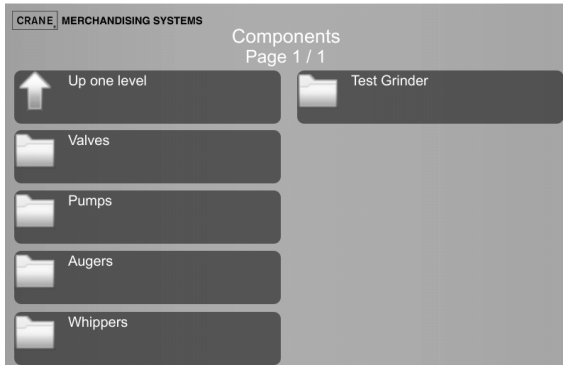

5.5.2.1 Valves

Use this option to test the correct operation of each individual dispense valve fitted to the heater tank, the dispense head will also move to its fully extended position.

1. Water will be dispensed from the heater tank during the test sequence. Place a suitable container under the dispense position and on completion empty the contents of the container.

N.B. In this test the valves are each energised for 4 seconds, allowing an accurate calibration of volume via the restriction on the valves.

 **Important:** Keep hands away from the dispense area as hot water is dispensed during the test.

5.5.2.2 Pumps

Use this option to test the correct operation of the syrup pumps if fitted.

1. Touch the relevant Pump to prime it.

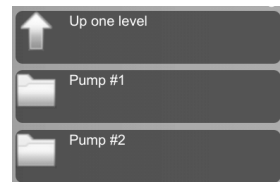

5.5.2.3 Augers

Use this option to test the correct operation of each individual ingredient motor. This test causes the ingredient canister auger to turn, remove the canisters before starting the test sequence.

 **Important:** DO NOT place ingredient canisters on the floor.

1. Each **Auger** on the machine is listed and can be tested individually or by using the **Testing** option a test sequence of each can be run.
2. An **Abort** option enables the **Testing** sequence to be stopped at any time.
3. Refit the ingredient canisters on completion of the test.

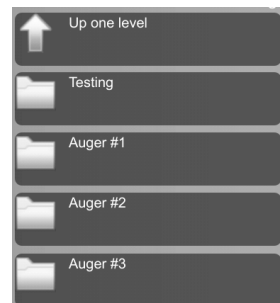

5.5.2.4 Whippers

Use this option to test the correct operation of each individual whipper motor, each motor is run for 4 seconds.

1. Each **Whipper** on the machine is listed and can be tested individually or by using the **Testing** option a test sequence of each can be run.
2. An **Abort** option enables the **Testing** sequence to be stopped at any time.

5.5.2.5 Test Grinder

Use this option to test the correct operation of the coffee bean grinder motor, it will run for 4 seconds.

5.5.3 Keypad

This menu enables the engineer to test each touch area on the drink selection interface and internal service keypad to ensure correct operation.

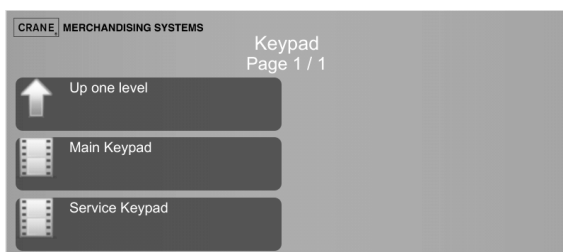

5.5.3.1 Main Keypad

Select **Main Keypad** to test the drink selection keypad the screen displays blank menu options.

1. Press each touch-key on the drink selection interface (once only) a bleep and a flag icon appears against the touch-key pressed indicating that the touch-key is operating correctly.
2. Touch each blank menu option to display a flag icon.
3. When complete press the top left touch-key or menu option three times.

5.5.3.2 Service Keypad

1. Select **Service Keypad** to test the buttons.
2. An image of the Service Keypad is displayed.
3. Locate the keypad on the rear of the door and press each key to test its operation.
4. As each key is pressed the corresponding key on the screen is highlighted.

5.5.4 Coin Return Motor

This menu enables the engineer to test the operation of the coin return motor.

1. While the test is running the 'test animation' accompanied by a **Please Wait** message, on a successful completion of the test the screen returns to the **Test** screen.

5.5.5 Display

This menu option enables the engineer to test the **LCD** display screen.

1. Select **Display**, the **LCD** display cycles through a range of colours.
2. The above tests reveal any flaws in the **LCD** screen.
3. When complete, touch the screen to return to the **Test** menu.

5.5.6 Door Lights

This test illuminates each LED in sequence and the following message is displayed along with the test animation.

Performing door light tests (part 5/7). You should see some changes with door lighting

5.5.7 Dispense Head

This menu enables the engineer to test the operation of the dispense head mechanism, moving through all vend positions before return to its 'home' position.

1. While the test is running the 'test animation' accompanied by a **Test Started** message.
2. On completion of a successful test the screen returns to the **Dispense Head** screen. If the dispense head fails to move a **Moving Failed** message is displayed and you are asked to **Continue**, returning to the **Dispense Head** screen.
3. Four test positions are available; **Home**, **Vend Position 1**, **Vend Position 2** and **Fully Extended**.

5.5.8 Vend Without Cup

This menu enables the engineer to test vend all of the drinks that are available from the machine without dropping a cup, to ensure each drink is correctly dispensed.

A suitable container must be placed under the dispense position to receive the vend. While the tests are running the 'test animation' accompanied by a **Test Started** message, on a successful completion of the test the screen returns to the **Vend Without Cup** screen.

1. Select the required drink to be tested.
2. The ingredient, milk and sugar strengths can be changed using the – and + to change the values as required.
3. Select **Start** to start the vend process.
4. Each drink can be tested as required by repeating the procedure above.

5.5.9 Vend With Cup

This menu enables the engineer to test vend all of the drinks that are available from the machine into a cup, to ensure each drink and cups are correctly dispensed. While the tests are running the 'test animation' accompanied by a **Test Started** message, on a successful completion of the test the screen returns to the **Vend With Cup** screen.

1. Select the required drink to be tested.
2. The ingredient, milk and sugar strengths can be changed using the – and + to change the values as required.
3. Select **Start** to start the vend process; drop a cup and dispense the drink.

N.B. If the SureVend™ system is turned on the sensors must be activated within 3 seconds of the cup being dispensed, refer to Section 5.7.10 SureVend™.

4. Each drink can be tested as required by repeating the procedure above.

5.5.10 Cup Drop

This menu option enables the engineer to test the operation of the cup drop unit to ensure a cup is dropped.

While the test is running the 'test animation' accompanied by a **Cup Dropping** message, on a successful completion of the test the screen returns to the **Test** screen.

5.5.11 CoEx Module

This menu enables the engineer to test the operation of the CoEx module components. While the tests are running the 'test animation' accompanied by a Test Started message, on a successful completion of the test the screen returns to the CoEx Module screen.

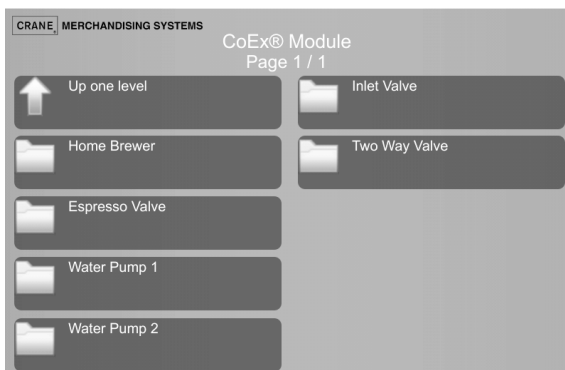

5.5.11.1 Home Brewer

Use this option to ensure that the brewer is able to reset and return to the home position.

5.5.11.2 Espresso Valve

Use this option to test the correct operation of the espresso valve.

5.5.11.3 Water Pump 1 and 2

Use this option to test the correct operation of the water pump or pumps as fitted to the machine.

5.5.11.4 Inlet Valve

Use this option to test the correct operation of the inlet valve.

5.5.11.5 Two Way Valve

Use this option to test the correct operation of the pressure valve.

5.5.12 Stick Stirrer

Use this option to test the correct operation of the Stick Stirrer dispenser.

5.5.13 Water Tank Module

Use this option to purge a new or exchanged water filter. When selected water flows through the water filter for 60 seconds.

5.6 Price

This menu allows the engineer to enter individual prices for each drink selection available, one price for all drink selections, set a discount for consumers who use their own cup/mug and view the highest and lowest price set in the machine.

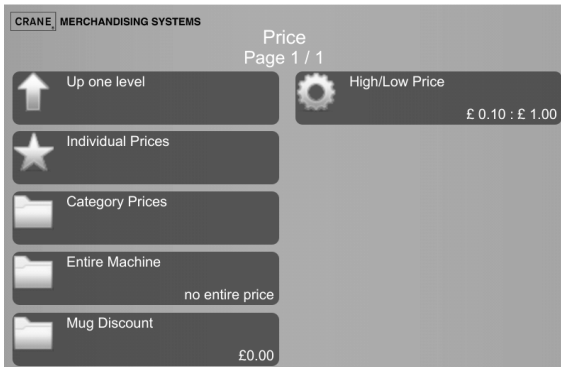

Tip: If most selections are to be sold at the same price, use the **Entire Machine** menu to quickly set the entire machine to this price, then access the **Individual Prices** menu to adjust prices for individual selections. Entering a single price for the entire machine will over-ride any individual prices previously programmed.

5.6.1 Individual Prices

This option enables the price of each drink to be set. Each drink selection is shown with the current price, select the required drink and enter the new price in the value entry screen.

5.6.2 Category Prices

This option enables prices to be set for categories of drinks i.e. all coffee bean based drinks.

5.6.3 Entire Machine

This option enables a single price to be set for all drinks from the machine. Enter the new price in the displayed value entry screen.

5.6.4 Mug Discount

This enables a discount value against all drink selections for consumers who use their own cup/mug.

1. Select and enter the discount amount in the value entry screen.
2. When a consumer places their own cup into the dispense area and selects a drink, the SureVend™ sensors detect the cup and disables the cup drop mechanism. The value set for **Mug Discount** is then subtracted from the price of the drink selected and the appropriate change/credit returned to the consumer.

N.B. It is important to ensure that any value entered for a mug discount is supported by the coin mechanism fitted to the machine e.g. if a mug discount is set at 2p but the lowest coin available from the coin mechanism is 5p the machine will not be able to return the discount to the consumer.

5.6.5 High/Low Price

This displays the price range from lowest to highest on the machine. If a single price is set across the machine this is indicated by the same price appearing in both fields.

5.7 Product Configuration

This menu enables all aspects of the drinks to be adjusted, from temperature and ingredients to how they are dispensed and the management of water quality and waste.

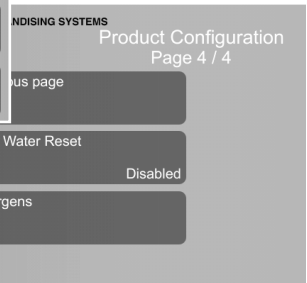
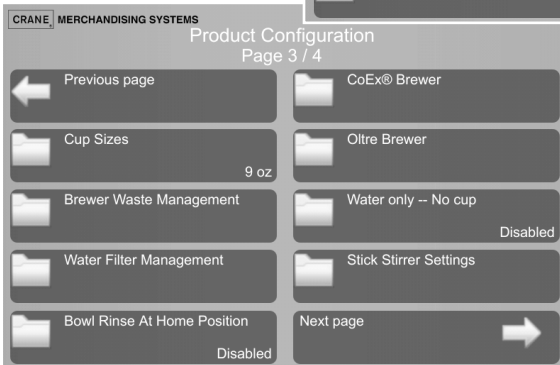
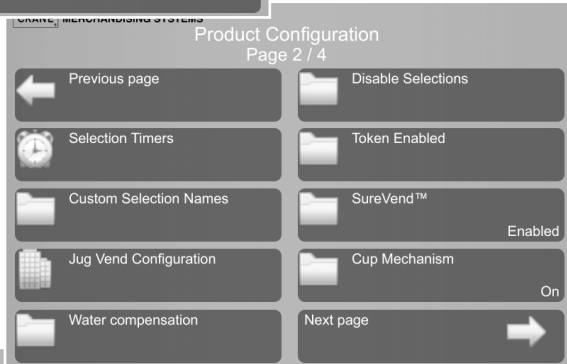
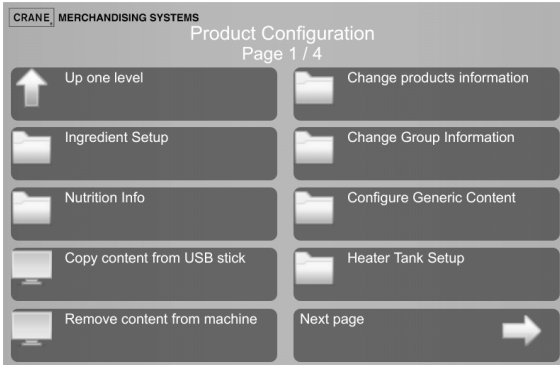

5.7.1 Ingredient Setup

This menu option enables the amount of product that is dispensed per vend to be weighed. The data collected, the amount of ingredient used per vend, can be used by a back-office stock system to determine the use and visit frequency requirements to restock/service the machine.

The system runs each auger/grinder three times for four seconds, the ingredient must be weighed each time and the value entered, the average grams/second of that ingredient is then calculated. This procedure is repeated for each ingredient canister and the averages stored in the machine.

CoEx Brewer calibration, refer to Section 5.7.4.1, must be performed before this proceed to set the required amount of dispensed coffee.

5.7.1.1 Canister/Grinder Calibration

This option displays all the ingredients available in the machine and enables each ingredient to be selected and the average weight of a 'dispense' to be calculated.

1. Select the ingredient to be weighed.

The ingredient is initially primed and ingredient dispensed, discard this ingredient.

2. The next series of screens enable the ingredient to be dispensed, the ingredient weighed and the value entered and saved.
3. Select **Start** to dispense the ingredient, when dispensed weigh the ingredient and enter the amount on the displayed keypad.

This process is repeated three times, when the third value is entered the machine calculates the average weight of the three values, this is then saved.

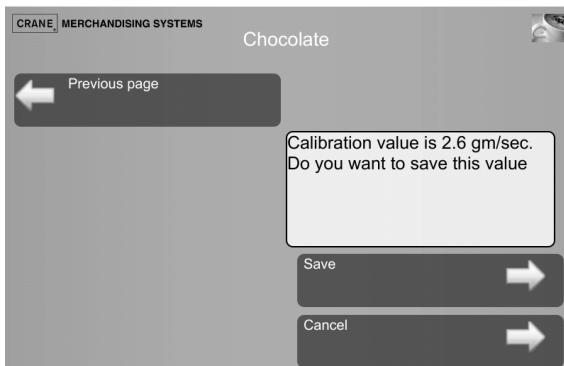
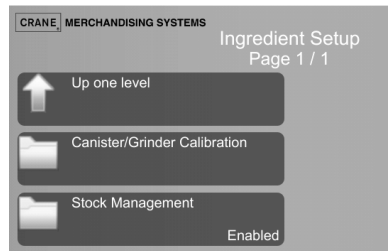

4. Repeat this procedure for each ingredient.

5.7.1.2 Stock Management

This option enables the use of the saved Canister/Grinder Calibration data by the Crane Vendmax route management tools to determine stock usage.

1. This screen enables **Stock Management** to be **Enabled** or **Disabled**.

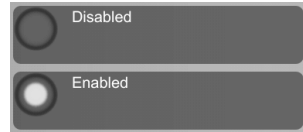

5.7.2 User Interface

The next six options on this screen enable the User Interface to be customised, refer to **Section 4—Customising the User Interface** for more details.

- Nutrition Info
- Copy Content from USB Stick
- Remove Content from Machine
- Change Products Information
- Change Group Information
- Configure Generic Content.

5.7.3 Heater Tank Setup

This option enables the target water temperatures in the tank, the minimum temperature for a drink to be set and displays the current tank temperature.

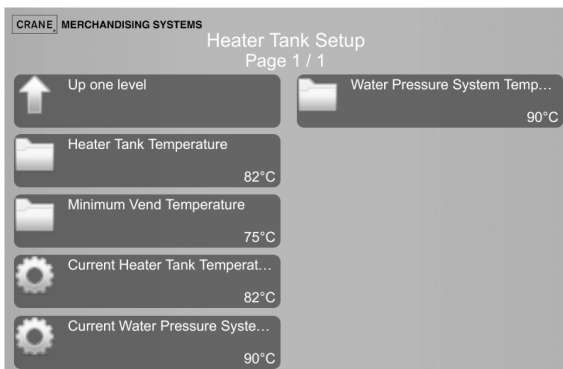

1. **Heater Tank Temperature**—to set the gravity tank temperature.
2. **Minimum Vend Temperature**—to set the minimum vend temperature.
3. **Current Heater Tank Temperature**—shows the current gravity tank temperature.
4. **Current Water Pressure System**—shows the current espresso heater temperature.
5. **Water Pressure System Temper**—to set the espresso heater temperature.

5.7.4 Selection Timers

This menu enables the drink recipes to be adjusted to suit individual preferences. Each drink available on the machine can be adjusted and each has default values. Selecting a drink displays the ingredients that make up the drink and timers to make the drink and are explained below:

1. Select the drink from the **Selection Timer** menu to display the ingredients that make up the drink.
2. **PreVend** – this is factory set to optimal values and should not be changed.
3. **Milk, Sugar and Instant Coffee** – these ingredients can be adjusted to offer different strengths to the user and appear in this menu as for example **Milk 1, Milk 2 and Milk 3**, where **Milk 1** is the least amount of milk and **3** is the most. The strength is measured in seconds and controls how long the ingredient motor is run and is known as the ingredient throw.
4. Each ingredient can be adjusted in this way and the following can also be adjusted to create the drink.
5. **Water Quantity** – how long the water valve is opened.
6. **Product Delay** – to delay the adding of product after a valve opens.
7. **Whipper Time** - how long the whipper is run.
8. **Whipper Delay** – to delay the whipper after a valve opens.
9. **Post Dispense Delay** – this is the length of time the dispense head remains in the extended position after the last ingredient has been vended.

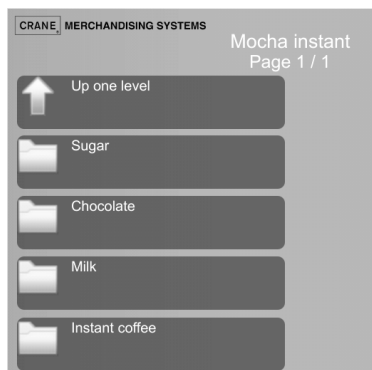

5.7.4.1 CoEx Brewer Calibration

The CoEx brewer must be calibrated to ensure it delivers the correct amount of coffee to satisfy consumers taste preferences. The following two calibrations must be performed before any of the above **Selection Timers** or **Water Compensation**, refer to Sections 5.7.4 and 5.7.7, are adjusted.

Grinder Adjustment

1. To adjust the grinder, select a drink that contains **Coffee Beans** “Espresso made from Beans” for example from the **Selection Timer** screen.
2. Select the **Coffee** option and then **Selection Timer** to display the **Timer** screen and show the **Timer** figure.
3. Press button **15** on the **Service Keypad**, to dispense a quantity of ground coffee for the amount of seconds displayed.
4. Check the consistency of the coffee grind & adjust if required. This also enables you to weigh the coffee & adjust the gram throw figure.

Auger Calibration

1. To calibrate the auger, select a drink that contains **Fresh Coffee** from the **Selection Timer** screen.
2. Select the **Coffee** option and then the **Selection Timer** to display the **Timer** screen to show the **Timer** figure.
3. Press button **15** on the **Service Keypad**, to dispense a quantity of fresh coffee for the amount of seconds displayed.
4. This enables you to weigh the coffee & adjust the gram throw figure.

5.7.5 Custom Selection Names

This menu enables syrup based drinks and soups to be given a name that appears on the drink selection screen. The types of drinks available are displayed and selecting the required type displays names that are available.

1. If for example soup is available, select **Soup** to display a list of soups.
2. Select the type of soup, in this example **Tomato**.
3. **Tomato Soup** will now be shown on the drink selection screen.

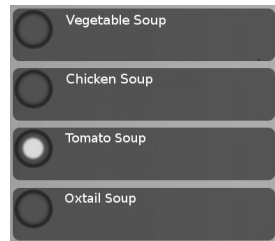

5.7.6 Jug Vend Configuration

This menu enables the selection of drinks available for jug vend, the number of cup vends per jug and to enable SureVend™.

1. **Enable Selections** – use this option to select the drinks that are to be available for jug vends.
2. **Setup Selections** – use this option to enter the number of vends per jug.
3. **SureVend™ for Jug Vend** – use this option to enable/disable SureVend™ should a glass jug be used.

5.7.7 Water Compensation

This sub menu enables the engineer to set the Espresso water system to vend the correct amount of water for individual site operating conditions.



Important! Grinder and Auger Calibration, refer to Section 5.7.4.1, must be carried out before setting the **Water Compensation**.

The goal is to vend the programmed amount of water (in Selection Timers) during a vend. Increase or decrease the number until the correct volume of liquid is dispensed during a Freshbrew or Espresso vend cycle.

1. **FB Compensation:** Freshbrew - low pressure drinks.
2. **Esp Compensation:** Espresso - high pressure drinks .

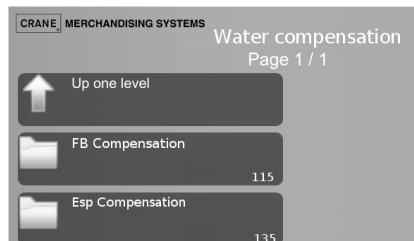

5.7.8 Disable Selections

This menu enables individual drinks to be temporarily disabled.

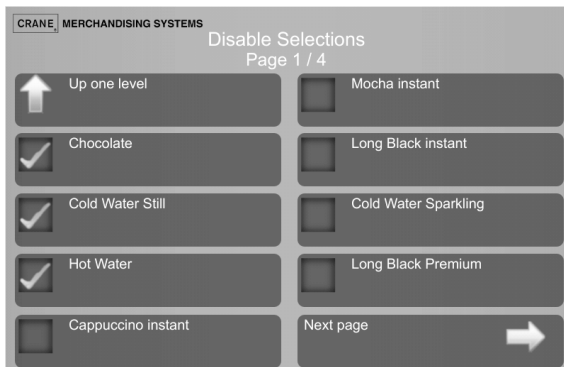

1. Select the drinks to be removed (disabled) from the drink selection menu.
2. A tick indicates the drink to be disabled.
3. Select a ticked drink to enable the selection.

5.7.9 Token Enabled

This enables the selection of those drinks that can be dispensed using a token.

5.7.10 SureVend™

This menu enables the SureVend™ product delivery sensor to be **Enabled** or **Disabled**.

SureVend™ Overview:

1. SureVend™ ensures that a cup is always available in the cup station before any money is collected or product delivered. The sensing system is a beam of infra-red light across the cup station that is broken by a cup as it falls into position from the cup drop unit or by a consumer placing his own mug in the dispense area.
2. The SureVend™ software monitors the cup station sensor during the time that the cup ring is operated and for three seconds afterwards. If a cup is not detected the software will then attempt to drop a cup a second time and if necessary a third time after which the consumer's money is returned.
3. The machine remains in service and the machine will accept another consumers vend request and payment and will attempt to drop a cup a further three times. If a cup is still not detected the consumer's money is again returned.

The machine will now accept a third consumers payment and attempts to drop a cup three more times. If these attempts fail the consumer's money is returned and the message "Out of Cups" is displayed.

4. To clear the message and return to standby mode, open the door.
5. Check and if necessary clear the cup drop unit. Ensure correct operation before leaving the machine.

5.7.11 Cup Mechanism

This enables the cup drop unit to be switched **On** or **Off**. If user's own cups are to be used set this to **Off** to disable the cup drop unit, SureVend™ can still be used to monitor the dispense area and will not dispense drinks without a cup in the dispense area.

5.7.12 Cup Sizes

This indicates the cup size used in the machine and must be set to match the cups size used, refer to Section 2.6 - Cup Drop Unit Set Up.

5.7.13 Brewer Waste Management

If this feature is **On** it enables the number of fresh brew drinks dispensed to be limited before the brewer waste bucket is emptied ensuring the bucket is not over filled.

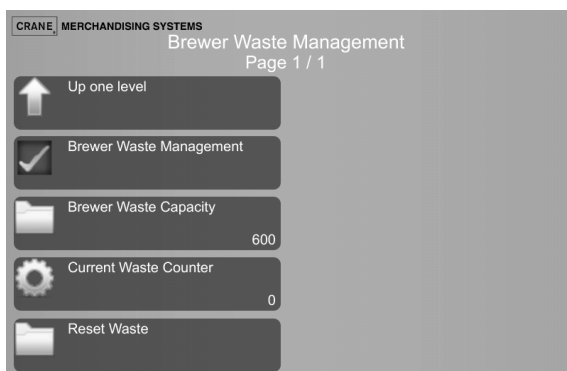

1. **Brewer Waste Management** - check this box to enable.
2. **Brewer Waste Capacity** - enter the number of vends before the fresh brew drinks are disabled and the waste bucket emptied.
3. **Current Waste Counter** – this indicates the number of fresh brew drinks dispensed.
4. **Reset Waste** – this resets the counter with a warning.

N.B. If this feature is **On** the operator must press button **12** on the Service Keypad every time the brewer waste bucket is emptied.

5.7.14 Water Filter Management

This enables an indication of when the water filter requires changing. A litre count or time period can be used and whichever is reached first displays an alternating message 'Water Filter Change Required' on the standby screen although the machine remains operational.

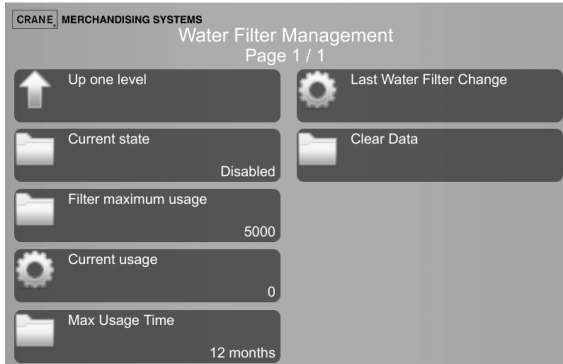

1. **Current State** – Enable or Disable this feature.
2. **Filter Maximum Usage** – specify the maximum number of litres through the filter, the default is 5000.
3. **Current Usage** – this indicates current litre count.
4. **Max Usage Time** – enables a set time period to be entered after which the change filter message is displayed.
5. **Last Water Filter Changed** – this indicates the date and time of the last filter change.
6. **Clear Data** – resets the counter with a warning.

5.7.15 Bowl Rinse

This enables the Bowl Rinse and CoEx Clean (Service Keypad buttons **3** and **11**) to be used with the dispense head in the home (back) position. The dispense head remains over the waste bucket, removing the need to move the bucket forwards.

5.7.16 CoEx Brewer

This menu enables the following options for the CoEx brewer to be set-up.

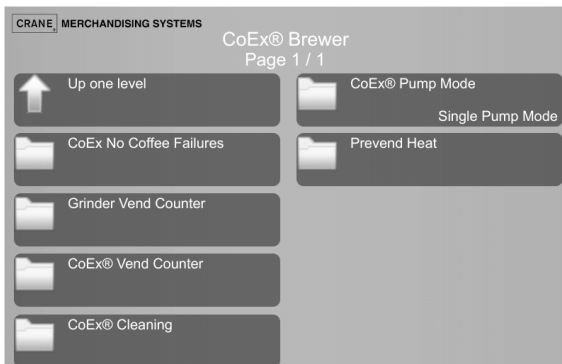

1. **CoEx No Coffee Failures** - indicates the total number of vend failures, the number since the last reset and a reset option.
2. **Grinder Vend Counter** - indicates the number of grinder vends and a reset option.
3. **CoEx Vend Counter** - indicates the number of vends and a reset option.
4. **CoEx Cleaning** - This enables a warning to be displayed when the CoEx brewer requires cleaning and if ignored the drink selections using the CoEx brewer are withdrawn. If this option is disabled no such warning is displayed and the CoEx brewer can continue to be used.
5. **CoEx Pump Mode** - This indicates the installed pump mode, either **Single** or **Dual**.
6. **Prevend Heat** - This enables the brewer components to be flushed through with hot water after a period of inactivity. This flush ensures the brewer components are warm and therefore the vend hot.
 - **Enabled/Disabled** - to enable or disable the Prevend Heat option.
 - **Water Quantity** - enables the amount of hot water used during the flush to be set.
 - **Inactivity Period** - the period of time after the last vend the flush will occur.

5.7.17 Oltre Brewer

This menu enables the Oltre brewer configurations to be viewed and set-up:

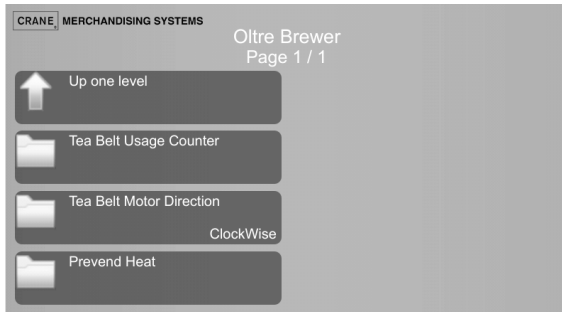

5.7.17.1 Tea Belt Usage Counter

Indicates the number of times the brewer belt has been used.

5.7.17.2 Tea Belt Motor Direction

These two indicate the direction the brewer belt is driven and must not be changed.

5.7.17.3 Prevent Heat

This enables the brewer components to be flushed through with hot water after a period of inactivity. This ensures the brewer components are warm and therefore the vend hot.

1. **Enabled/Disabled** - to enable or disable the Prevent Heat option.
2. **Water Quantity** - enables the amount of hot water used during the flush to be set.
3. **Inactivity Period** - this is the period of time after the last vend the flush will occur and can be adjusted here.

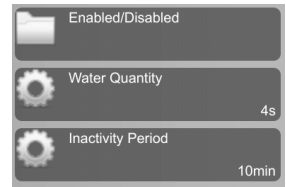

5.7.18 Water Only - No Cup

This disables the cup drop unit and forces the user to dispense Hot and Cold water using their own cup. If SureVend™ is enabled the user's cup must be in the dispense area before the water is dispensed.

5.7.19 Stick Stirrer Settings

This menu enables the configuration of the dropping of a Stick Stirrer, depending on the drink dispensed and when.

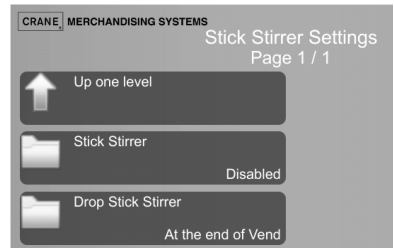

5.7.19.1 Stick Stirrer

This option enables the Stick Stirrer option to be used and which drinks receive a stirrer.

1. **Disabled** - this disables the Stick Stirrer, no stirrers are dropped.
2. **All Selections** - a Stirrer is provided for all drinks.
3. **Pre set selections** - a Stirrer is provided for all drinks with sugar (as defined in the drinks configuration).

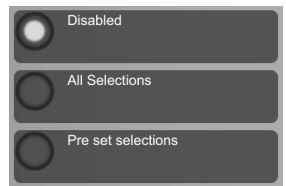

5.7.19.2 Drop Stick Stirrer

This option enables the Stirrer to be provided either:

1. **At the end of Vend**
2. **At the start of the Vend**

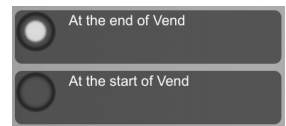

5.7.20 Low Water Reset

In normal operation a machine will only allow the main tank to fill for two minutes after which the inlet valve will be closed and the machine turned off until the machine is power cycled. This feature enables the water inlet valve to be opened more frequently.

It is not recommended to enable this feature as it could have adverse effects on the machine if there were a leak from the internal pipe work of the machine.

5.7.21 Allergens

This enables any allergens in the selected drink to be displayed, refer to Section 4.11 for more information.

5.8 Menu Setup

This menu enables the position of the available drinks on the drink selection menu to be changed. A maximum of seven drinks can be offered on one menu if more are offered further menus (or Page 2/2) are displayed. The first option on this menu enables the position of a back icon to be positioned.

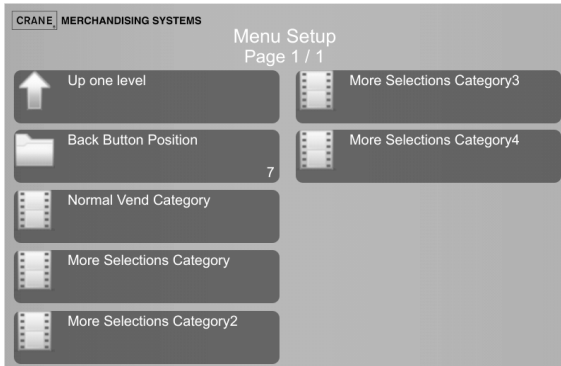

1. **Back Button Position** - if the drink selection menu runs over to a second screen this option enables the **Back Button** to be positioned on the second screen.
Six drinks can be displayed on each drink selection menu. If the second screen has only four drinks the **Back Button** can be positioned directly underneath the fourth drink at position 5, or 7 if there are six drinks.
2. **Normal Vend Category** – these are the drinks available from the first drink selection menu.
3. **More Selections Category 1 to 4** – if there are more than six drinks available from the machine they are displayed on this drink selection menu.

Selecting one of the above category options displays the screen below and shows the alternate drink labels that can be placed on the drink selection menu.

1. **Leave unchanged** – leaves the original drink in the menu.
2. **Empty** – clears the drink from the menu.
3. All additional drinks are displayed and can be selected to replace the original drink.

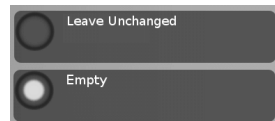

5.8.1 To change the menu

1. Select the menu **Category** that is to be changed, the current drink selections are displayed.
2. Select the drink that is to be removed or moved.

- 3. Select new drink or select **Empty**.

If left as **Empty**, the words **Empty slot** indicate that a blank space will appear on the consumer drink selection menu.

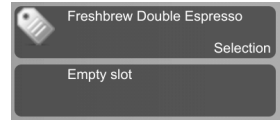

- 4. Select **Up one level** to display the new selection on the **Category** screen.
- 5. Select **Save** to save the change and return to the **Menu Setup** screen.

Tip: Using these screens you can group drink types together or if there are less than seven drinks you can leave empty slots at the bottom of the screen.

5.9 Free Vend

This enables the user to dispense drinks free of charge, if enabled it overrides all prices.

5.10 Money

This menu enables the type of coin/card mechanism or note reader fitted to the machine to be selected, to configure the coin set, values for low change, multiple vends and credit for failed vends. The options available on this menu depend on which options are selected.

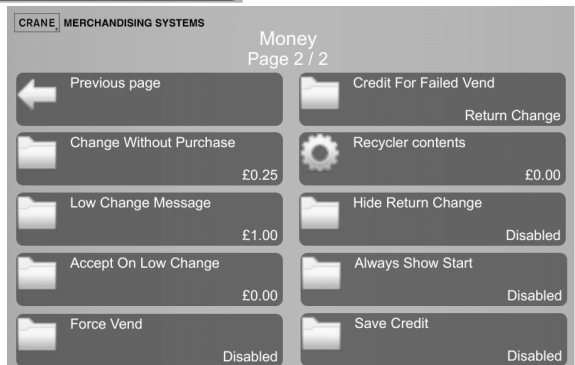
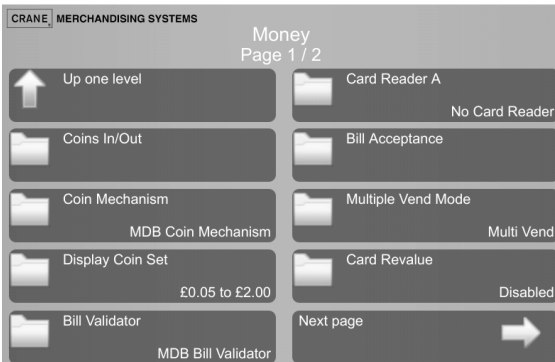

5.10.1 Coins In/Out

This displays the totals of coins through the coin mech, a table displays: the total **Coins**, **Count** and **Value** of the coins.

- To load the coin mech tubes with change select the required tube.



5.10.2 Coin Mechanism

This enables the coin mechanism fitted to the machine to be selected, including the options:

- No Coin Mechanism**, for machines not charging for drinks.
For machines not fitted with a coin mechanism other payment devices may be fitted.
- MDB Coin Mechanism** and **Exec Coin Mechanism**.
Selecting **Exec Coin Mechanism** requires the Executive kit to be fitted.



5.10.3 Display Coin Set

This enables which denominations of coins are displayed on the **User Interface**, refer to Section 4 for more information.

5.10.4 Bill Validator

This enables the **MDB Bill Validator** (if fitted) to be selected.

5.10.5 Card Reader

This enables the **MDB Card Reader** (if fitted) to be selected.

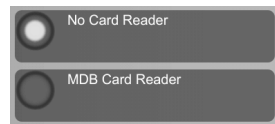

5.10.6 Bill Acceptance

This enables which denominations of bills (notes) are accepted.

5.10.7 Multiple Vend Mode

This menu is only applicable when a MDB Coin Mechanism is fitted to the machine and is Enabled on the Coin Mechanism menu. Two options are available:

- Multi Vend** - The user can make multiple vends as long as there is sufficient credit entered. In order to get change the consumer must press the coin return touch-key.
- Single** - Change is returned to the consumer automatically as soon as a valid selection is made.

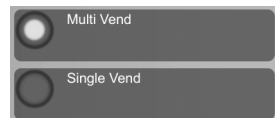

5.10.8 Card Revalue

If the **MDB Card Reader** is fitted, enabling the use of a payment card makes it possible for a user to pay cash into the machine to add credit to their card.

This menu enables this facility to be **Enabled/Disabled**.

5.10.9 Change Without Purchase

This menu is only seen when a MDB Coin Mechanism is fitted to the machine and Enabled on the Coin Mechanism menu.

The **Change Without Purchase** value specifies how and when the machine returns change to a consumer. If the consumer deposits credit into the machine which is less than or equal to the value set in the **Change Without Purchase** menu, change will be returned without a purchase. However, if the credit is larger the consumer must make a purchase before change will be given. For example:

1. **Value set to 1.00** - Non-escrowed coins less than or equal to £1.00 will be changed without purchase. All escrowed coins are returned.
2. **Value set to 0.00** - Forced Vend. This value forces the consumer to make a selection. No change will be returned without a purchase.

N.B. Each coin denomination for which the coin mechanism has a tube is called an Escrowed coin because it can be returned.

5.10.10 Low Change Message

This menu is only seen when a MDB Coin Mechanism is fitted to the machine and is Enabled on the Coin Mechanism menu.

1. When the total value of the coins in the coin mechanism falls below the value set on this menu the standby message displayed on the screen reads "Use Exact Change".
2. The machine will still accept money with this value set but may short change the consumer if there is insufficient coinage in the coin mechanism.

Tip: Set the Low Change Message and the Accept on Low Change values (5.10.12 **Accept on Low Change**) to the same figure to avoid the consumer being short changed.

5.10.11 Accept On Low Change

This menu is only seen when a MDB Coin Mechanism is fitted to the machine and is Enabled on the Coin Mechanism menu.

When the total value of the coins in the coin mechanism falls below the value set in the low change condition, the machine will stop accepting coins and notes for which it cannot return change. For example, if the engineer sets a value of £1.00 the machine will not accept a £1 coin if there is less than £1 value of coins in the coin mechanism.

5.10.12 Force Vend

If money has been put into the machine the user must complete a drink selection and vend a drink. The machine is unable to return their money or change until a vend has occurred.

This ensures the machine cannot be used as a change machine.

5.10.13 Credit For Failed Vend

This menu is only seen when a MDB Coin Mechanism is fitted to the machine and is Enabled on the Coin Mechanism menu.

When a vend fails the machine can do one of two things:

1. **Return Change** - The consumers change is immediately returned after a failed vend.
2. **Hold Credit** - The consumers credit is retained, allowing them to either make an alternative selection or press the coin return.



5.10.14 Recycler Contents

This displays the value of notes currently in the Recycler.

5.10.15 Hide Return Change

When this is enabled an extra 'Start' button is added to initiate a vend before credit authorisation is required (a requirement of some older cashless devices).

5.10.16 Always Show Start

When this is enabled an extra 'Start' button is added to initiate a vend before credit authorisation is required (a requirement of some older cashless devices)

5.10.17 Save Credit

When this is enabled credit remains indefinitely in the machine.

When disabled unused credit is removed after 5 minutes of inactivity.

5.11 System Settings

This menu enables the machine to be set up using the following menus.

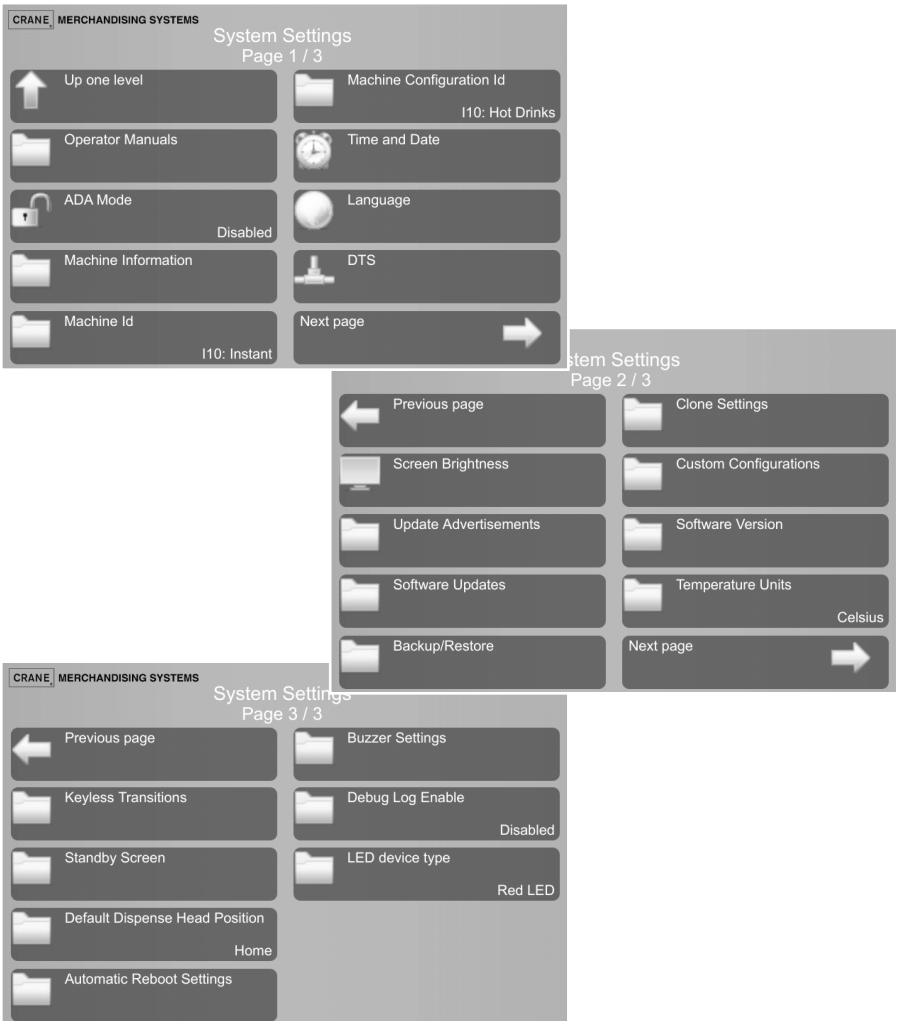

5.11.1 User Interface

The first two options on this screen enable the User Interface to be customised, refer to Section 4—**Customising the User Interface** for more details.

- Operator Manuals
- ADA Mode.

5.11.2 Machine Information

This enables details of the machine and contact information to be entered. This information can be displayed on screen if the machine develops a fault and is inoperable. It enables an engineer to be contacted and the machine identified.

1. **Show/Hide Machine Information** – this enables the information entered to be displayed on the screen if required.
2. **Contact Number** – this enables a contact phone number to be entered. New numbers can be added, deleted and any previous numbers used are shown.
3. **Machine Id** – each individual machine can be named to help with identification and is shown in the DEX report.
4. **Machine Location** – the location of the machine can be added to help with identification and is shown in the DEX report.
5. **Custom Configuration Name, Manufacturer ID, Model Number and Board Serial Number** this information is displayed on screen and identifies the machine system set.

5.11.3 Machine Id

This identifies the machine by the configuration of drink types it is setup to vend.

E8CI – Instant machine

I6CF – Freshbrew machine using Oltre brewer

I5CF – Espresso/Bean to Cup machine (With/without Oltre brewer tea brewer

I5CF-RG – Freshbrew (no grinder) Espresso machine (with/without Oltre tea brewer).

5.11.4 Machine Configuration Id

This enables the drink types to be selected that are available based on the Machine Id.



5.11.5 Time and Date

This enables the **Time Zone**, **Time** and **Date** of the machine's location to be selected.

1. In the **Time** menu there is the option to use either a 12 or 24 hour clock display.

5.11.6 Language

This menu enables the selection and installation of different languages on the machine. The installed languages are displayed and additional languages can be installed from a USB stick. Different languages for the consumer (user) and the service engineer can be used simultaneously.

1. **Install Language** – to install a new language it must be available on a suitable USB stick and file format.
2. **Remove Languages** – this removes current languages installed on the machine. As a safe guard you cannot remove all languages from the machine.
3. **Service Application** – this enables the selection of the language that is used on all screens accessed by service engineers.
4. **User Interface** – this enables the selection of languages that are available for selection by the consumer (user). A default language can be selected with the option to provide a further four languages that are available for the consumer to select on the drink selection screen.

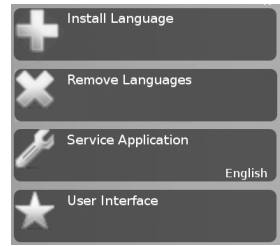

5.11.7 DTS

This menu enables the configuration of the data transfer standard to send audit data relating to sales and events, stored in the machines memory, to a data carrier or other device.

Data Transfer Standard (EVA-DTS): This is the standard that makes it possible to transfer information from vending machines/payment systems to PC-based accounting/management systems and/or the opposite way. It is important that all suppliers of vending machines and payment systems agree to a common standard for the Electronic Data Transfer because only this way the operator can be sure that all his equipment can be read out and programmed by means of the same handheld device.

5.11.7.1 DTS Standby Mode

This indicates the current mode and is factory set to enable data transfer via:

1. **DDCMP IrDA** - data can be downloaded from the machine using a hand held infra red DDCMP device.
2. **DEX** - data can be downloaded from the machine by plugging a DEX enabled device into the DEX port (J16) on the main control board, located on the rear of the door.
3. **DDCMP Wired** - data can be downloaded via a plugged in DDCMP device.

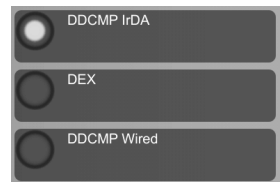

5.11.7.2 DTS Audit List

This menu enables the selection of which data is transferred from the machine to a DEX/DDCMP data carrier. All data and events fields within a vending machine are assigned a unique code determined by the DTS and these fields are available for selection on this screen.

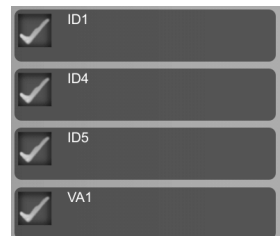

5.11.7.3 CA304 Data Type

This menu determines whether the data will be displayed as **Currency** or **Numeric**.

1. For example, assuming that the value of pound coins in the machine is £3.00, when set to **Currency** CA304 will read 300 in the DEX/DDCMP report.
2. When set to **Numeric** it will read 3.

5.11.7.4 Data Reset Mode

This menu enables all resettable data to be either saved or reset to zero, select:

1. **Auto** - to reset the data after a successful read.
2. **Save** - to save the current data values held on the machine.

5.11.7.5 Event Reset Mode

This menu enables all event data to be either saved or reset to zero, select:

1. **Auto** - to reset the event data after a successful read.
2. **Save** - to save the current data held on the machine.

5.11.7.7 Printer Baud Rate

This enables the correct baud rate for a serial printer to be set if one is to be used. It is important for this to be set correctly to ensure successful data transfer.

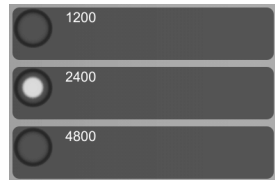

5.11.7.8 Passcode Reset

Data collection is passcode protected, but the machine is able to remember the passcode of the collection device. If a different device is used that the machine does not recognise the passcode must be reset to enable the transfer of data.

This option enables the passcode to be reset, a warning is given to confirm the reset is required.

5.11.8 Screen Brightness

This menu enables the brightness of the drink selection screen to be adjusted when in normal operating mode and when in Power Saving Mode.

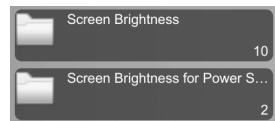

5.11.9 Update Advertisements

This option is for future development and is not currently available.

5.11.10 Software Updates

This menu enables new software versions to be uploaded onto the machine, via a USB stick.

5.11.11 Backup/Restore

This enables a backup of the current configuration on the machine and the ability to restore the default or available configurations.

1. **Make New Backup** - follow the on screen instructions to save the current machine configuration.
2. **Available Backups** - this enables a default configuration or any available (as listed on this screen) to be used on the machine.

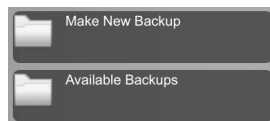

5.11.12 Clone Settings

This enables certain selected elements of a machine's configuration to be cloned and used on other machines. A USB stick is required to copy the configuration too.

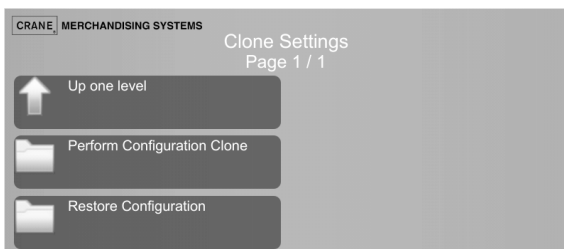

5.11.12.1 Perform Configuration Clone

Select this option to display the screen below to select the elements to be cloned and insert a USB stick into the USB socket on the Atlas H Board.

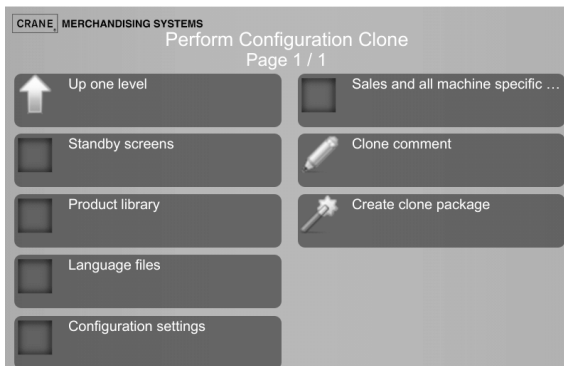

1. Select the elements to be cloned.
2. To label and identify the Clone select **Clone comment**, this displays a qwerty keyboard and the entry of a suitable label.
3. When complete select **Create clone package**.

5.11.12.2 Restore Configuration

Select this option to copy a Clone configuration on a USB stick onto the current machine.

1. Insert a USB stick with the required Clone configuration on into the socket on the Atlas H Board.
2. Select Restore Configuration to copy the Clone configuration across onto the machine.
3. When the copy process is complete a confirmation screen is displayed.

5.11.13 Custom Configurations

This enables a specific configuration available on the machine to be selected and installed.

5.11.14 Software Version

This displays the current software: **Release**, **I/O Board Version** and the **Kernal** version numbers.

5.11.15 Temperature Units

The enables the temperature to be displayed in either **Celsius** or **Fahrenheit**.

5.11 16 Keyless Transitions

This enables the user to vend into a jug or vend free of charge, however a passcode is required in both cases.

1. This can be **Enabled** or **Disabled** and a **Transition Time** entered after which the machine reverts to normal vend mode.
2. If this feature is enabled the consumer must select the **My Code** icon to display the **My Code** keypad. There are two possible codes:
 - Jug Vend
 - Free Vend
3. These codes can be set using the relevant options on the **Security Codes** screen, refer to Section 5.12 for more information.

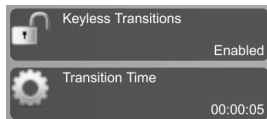

5.11.17 Standby Screen

This enables a standby screen to be displayed after the machine has remained idle for a set time. This function can be **Enabled** or **Disabled** and a **Transition Time** (or idle time) entered after which the Standby Screen is displayed.

It also enables the selection of the types Credit Cards and Bills/Notes that can be used in the machine. These are also displayed on the User interface for the consumer to see, refer to Section 4 - **Customising the User Interface** for more information.

5.11.18 Default Dispense Head Position

This is the position of the dispense head after a vend, the following two options are available:

- **Home** - fully retracted into the machine.
- **Fully Extended** - remains extended in the vend position.

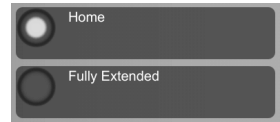

5.11.19 Automatic Reboot Settings

The machine is set up to reboot automatically at 2am, but only if the machine has remained idle for 300 seconds (5 minutes). These default setting can be changed to run at a more convenient time i.e.to suit work shift patterns.

- **Automatic Reboot** - This can be disabled but this is not recommended and should be left enabled.
- **Reboot Time** - This enables the reboot time to be changed, use the displayed screen to set the hours and minutes of the required reboot time. Once entered Save the new time.
- **Idle Time Seconds** - This is the period of inactivity seen prior to the reboot taking place, default is 300 seconds (5 minutes).

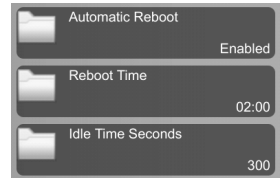

Enter the required period using the displayed numeric keypad.

Once entered Save the new time.

5.11.20 Buzzer Settings

This enables the sounds when touching the screen buttons to be varied.

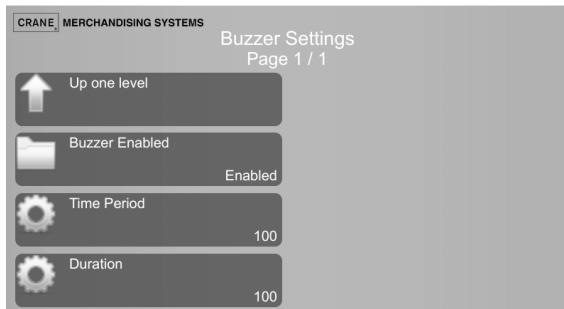

- **Buzzer Enabled** - This enables / Disables the buzzer.
- **Time Period / Duration** - These enable the sound of the buzzer to be changed. A numeric keypad enables a value to be entered to change the sound.

5.11.21 Debug Log Enable

This enables the capture of log files for fault analysis..

5.11.22 LED Device Type

This enables the selection of the LED colour scheme for the Display Screen.

1. Select the required colour type from those available on the **LED Device Type** screen to display the colours available in that type.
Only those types supported on the machine are displayed.

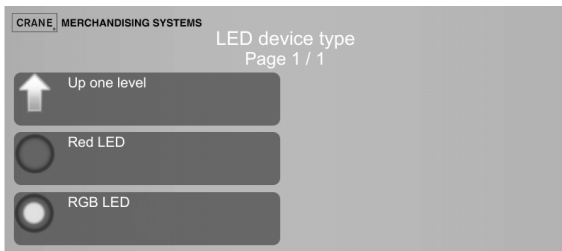

2. Selecting **Red LED** will display a red colour scheme on the Display Screen.
3. Selecting **RGB Led** type displays the following screen and the colour schemes available.

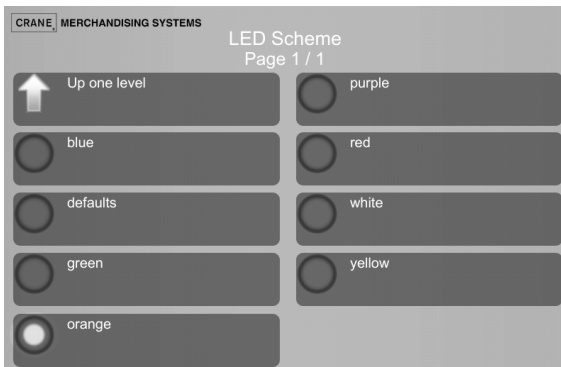

4. Select the required colour .

5.12 Security Codes

The security code for entry into the Engineer's Program is factory set so that the engineer presses the sequence of four numbers on the drink selection interface.

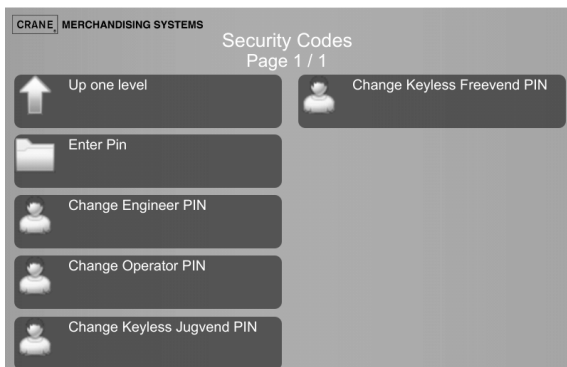

This screen enables these entry and keyless vend codes to be changed.



Important: On no account should the first three codes be altered without first consulting your supervisor or manager.

1. **Enter Pin** - this is the Supervisor's pin enables the following pins to be changed.
2. **Change Engineer PIN** - this displays and enables the pin to be changed, for entry into the Engineer's program.
3. **Change Operator PIN** - this displays and enables the pin to be changed for entry into the Operator's program.

N.B. It is highly recommended the following two codes are changed on all machines.

4. **Change Keyless Jugvend PIN** - this displays and enables the pin to be changed for the user to use a jug vend.
5. **Change Keyless Freevend PIN** - this displays and enables the pin to be changed for the user to use Freevend.

5.13 Timed Events

This enables the creation, deletion and update of timed events that are run automatically in the machine via the following menus.

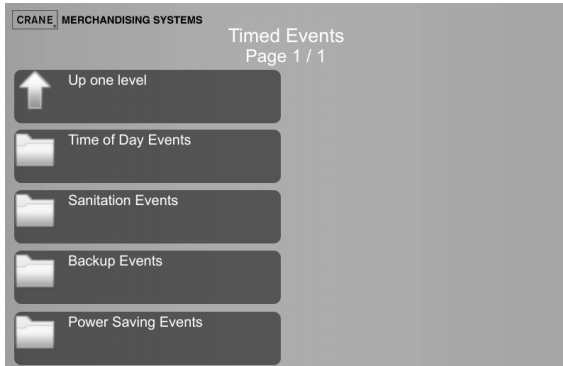

1. **Time of Day Events** - This enables the setup of discounted vend, free vend and inhibited vend periods.
2. **Sanitation Events** - This enables the setup of periods when the machine will automatically flush through the water system.
3. **Backup Events** - This enables the machine to be programmed to perform an automatic backup of all user configurable settings and sales data stored in its memory.
4. **Power Saving Events** - This enables the setup of periods when the machine enters a power saving mode. In this mode the water in the boiler is not maintained at the normal vend temperature, but at a lower temperature of 70°C.

The method for creating/updating a timed event is the same for all four event types. The following example describes how the engineer can program the machine to free vend specific drink selections between 10:30 am and 2:30 pm on week days.

Studying this example will provide an understanding of how timed events are created.

1. Select **Time of Day Events** on the **Timed Events** screen.

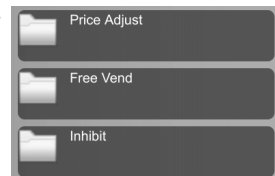

2. Select **Free Vend** to display the following screen.

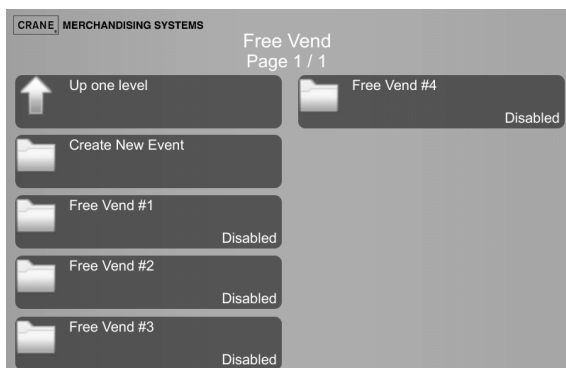

N.B. By default, four empty entries are available for free vend events. Additional events can be created by selecting **Create New Event**.

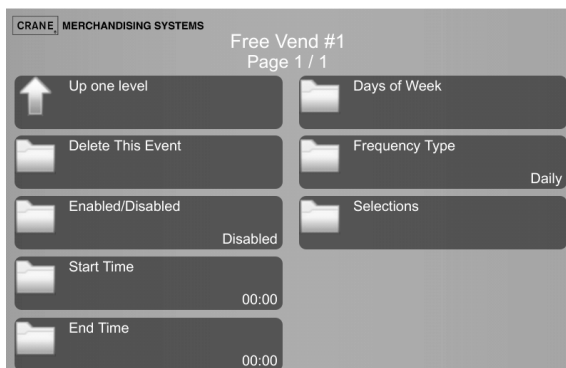

3. Select **Free Vend #1** to display the following screen.

N.B. By default the state is set to **Disabled** and the **Frequency Type** is set to **Daily**.

4. Select **Enabled/Disabled** and **Enable** to enable the event.
5. Select **Start Time** to display the **Start Time** screen.

N.B. You can switch to either **12hr** or **24hr** mode on this screen.

6. Set the start time to **10:30** and **Save**.
7. Select **End Time** to display the **End Time** screen.
8. Set the end time of **2:30 (14:30)** and **Save**.
9. Select **Days Of Week** and select on which days of the week Free Vend will be available. Individual days or **Select All** options are available.
10. **Frequency Type** - enables the free vend period to be either **Daily** or **Weekly**.
Daily - this enables a free vend period to be available on any selected day or all days of the week.

Weekly - this enables a free vend period to be available on a weekly bases, and can be set to be available over several days. A **Start** and an **End Day** can be selected.

11. Select **Selections**.
12. This screen enables the selection of which drinks are to be available for free vends on the days and between the times entered above.
The drinks selected here appear with no price against them on the drink selection screen.
13. All the required parameters for the event are now set and the screen below displays the following Free Vend event.

The screenshot shows a configuration screen for a 'Free Vend #1' event. The screen is titled 'Free Vend #1' and 'Page 1 / 1'. It features several interactive buttons and fields:

- Up one level**: A button with an upward arrow icon.
- Delete This Event**: A button with a folder icon.
- Enabled/Disabled**: A button with a folder icon, currently set to **Enabled**.
- Start Time**: A field showing **22:30**.
- Start Day**: A field showing **Friday**.
- End Time**: A field showing **02:30**.
- End Day**: A field showing **Sunday**.
- Frequency Type**: A field showing **Weekly**.
- Selections**: A button with a folder icon.

The event is **Enabled** and starts at **22:30** on **Friday** night, it finishes at **02:30** on **Sunday** afternoon and occurs **Weekly** for the selected **Selections** of drinks.

14. From this menu the engineer can quickly and easily set up additional **Time of Day**, **Sanitation**, **Backup** and/or **Power Saving Events** as required.

N.B. When setting a discount price event it is necessary for the engineer to enter a value for the discount as a percentage (%). If the machine is fitted with a coin mechanism, please ensure that the discount value entered is supported by the coin tubes.

5.14 Telemetry

This option is for future development and is not currently available.

5.15 Leave Service Application

This exits the Engineers Program and returns the machine to standby mode. Alternatively the machine door can be closed to exit the program and standby mode.

5.16 Machine Reboot

This initiates a reboot of the machine: powers it down and then restarts it, all configurations are kept.

A confirmation screen is displayed, with **Yes** and **No** options.

Section 6 - Service Keypad Functions

The machines is fitted with a service keypad mounted on the rear of the door. It enables the Operator to carry out specific functions during routine cleaning and maintenance.

N.B. During certain operations e.g. View Counters it is necessary for the operator to utilise the LCD mounted on the front of the door to access data.

This keypad enables the following functions:

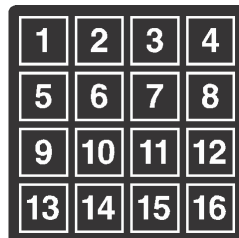

6.1 Button **1** - Program Entry

There is no functionality behind this button.

6.2 Button **2** - Brewer Open (Freshbrew Models Only)

This button operates the brewer and enables the engineer to replace the filter paper used in paper type brewers. Oltre brewers are cycled when using this button.

6.3 Button **3** - Rinse/Flush

1. The flush sequence rinses the mixing bowls. Before the sequence begins, the system waits until the water in the boiler is at the set temperature.
2. In order to guarantee the highest standards of cleanliness, the boiler fill valve is disabled ensuring that the water used in the sequence is delivered at the optimum temperature to kill any micro-organisms.
3. Each water valve and the corresponding whipper are switched on in sequence. Once the flush cycle is complete the machine returns to standby mode.

N.B. CoEx brewers are cycled and rinsed, Oltre brewers are not rinsed.

4. To flush the machine:

- Open the front door of the machine.

Caution: Ensure that a suitable container is placed under the dispense position. Keep hands away from the dispense area whilst the flushing cycle is in operation.

- Press and release the Flush button (3). The flush sequence begins.
- Empty the waste water container when complete.

6.4 Button **4** - Brewer Clean (Freshbrew Models Only)

1. The brewer clean button enables the brewer to be cleaned independently. In order to guarantee the highest standards of cleanliness the boiler fill valve is disabled, ensuring that the water used is delivered at the optimum temperature to kill any micro-organisms.
2. The brewer unit is filled with hot water and then operated through four complete brew cycles.
3. Once the cleaning cycle is complete the boiler refills and when the water is at the required temperature the machine returns to standby mode ready to vend.

6.5 Button **5** - View Counters

The View Counters button (5) enables the operator to access the Data Recall Menu. Entry into this menu allows the operator to view Non-Resettable and Resettable Sales Data, data relating to Timed Events, Identification Numbers of installed components and (if the feature is enabled) view SureVend™ assisted vend data. The Resettable Sales Data and SureVend™ Data menus contain an extra sub-menu which allows the operator to delete the current data from the machines memory. Refer to Para. 5.3 Data Recall Menu for full details relating to this menu and its contents.

6.6 Button **6** - Test Vend

The Test Vend button (6) enables the operator to vend a drink from the machine to ensure correct operation after cleaning or maintenance.

1. When the button is pressed and released the LCD will display the screen as shown opposite. Press a drink selection button followed by the **START/?** button to begin the vend sequence.
2. Ensure that the selection is correct, has not under/overfilled the cup and most importantly, tastes good!
3. Press the **X (Exit)** key on the drink selection keypad to exit from the Test menu and return to stand-by mode.

6.7 Button **7** - Cup Test

This button enables the operator to test the operation of the cup drop unit after refilling the cup stacks. When the button is pressed the cup drop motor is operated and a cup is ejected from the cup drop unit. This function ensures that the mechanism is working correctly.

6.8 Button **8** - Park Head

When this button is pressed, the dispense head moves to its fully extended position and stops. Press the button again to return the dispense head to its correct (homed) position.

6.9 Button **9** - Boiler Fill (Espresso Machines)

When this button is pressed the machine pumps a measured amount of water through the system - approximately 550ml, heating it as it does so. This ensures that heated water is immediately available when a drink is selected. This button should also be used to purge any water left in the system after the machine has been moved or shut down for any length of time.

Note: This should be used if there is an air lock in the closed loop system i.e. after an install or the machine has been serviced.

6.10 Button **10** - Machine Cool Down (Espresso Machines)

This button enables an engineer to work safely on the Espresso module.

When this button is pressed the hot water in the pressure system is replaced by 500ml of cold water. When complete the Message “Machine Cooled” is displayed and all outputs disabled, at this stage once the power to the machine has been disconnected the engineer can work safely on the Espresso module (refer to Para. 10.3 for full details).

6.11 Button **11** - CoEx® Tablet Clean (Espresso Machines)

This button when pressed, initiates the CoEx® brewer tablet cleaning routine. Crane Merchandising Systems recommends that this brewer cleaning routine should be carried out on a weekly basis (refer to the Operator’s Manual for full details).

6.12 Button **12** - Reset Waste Counter (F/Brew & Espresso Machines)

This is only relevant if the feature is turned on during installation.

Every time that the waste container is emptied the waste counter must be reset. Press button 12 on the service keypad. Two audible bleeps confirm that the counter has been reset to zero.

6.13 Button **13** - Syrup Prime (Still/Carbonated Machines)

This button enables the operator to prime the syrup selections after replacing a syrup container. Refer to Section 2.5 for full details of this operation.

6.14 Button **14** - Clear SureVend™ Error

This button enables the operator to simply and quickly clear SureVend™ errors caused by cup drop failures.

6.15 Button **15** - Start

This button has the same functions as the **START** key on the drink selection keypad.

Section 7 - Technical Information

7.1 Water Services

The mains water supply provides water for the heater tank and the pressure system fitted to Espresso machines. Water enters at the rear of the machine through a solenoid operated inlet valve operating at 24V DC which opens or closes the water supply as required.

7.2 Hot Water System

7.2.1 General

1. Water is heated in the heater tank to the required temperature by a heating element rated at 2.4 Kilowatts. The mains voltage required for the element is switched by a solid state relay controlled by the vending machine controller via an analogue signal transmitted by the thermistor probe.
2. The water level inside the heater tank is controlled by a water level probe. When the water drops below the required level the controller board operates the mains water inlet valve until the required water level is restored.
3. A series of 24V DC control valves are mounted on the outside of the heater tank. These supply heated water to each of the mixing stations where ingredients are added to make the drink. The "hot water" valve dispenses straight into the cup.
4. Should the inlet valve fail (or mains water supply be disabled), the controller board will detect a fault after the inlet valve 'open' signal has been active for 2 minutes and the required water level has not been reached.

At this point the keypad will be disabled, all outputs from the controller board (including the heater element) will be switched off and the LCD will show the message "Sorry Out of Service, Fill Timeout".

7.2.2 Espresso Machines

The water system fitted to Espresso machines is described in detail in this manual , refer to Section 8.2 - System Overview for full details.

7.3 Ingredient Dispense

1. The ingredients required for making up either an instant or freshbrew drink are contained in ingredient canisters and are dispensed by means of an auger located in the base of each canister. Each auger is driven by a 24V DC 128 RPM motor.
2. The amount of product dispensed by each canister is controlled by the vending machine controller and may be adjusted via the Selection Timers menu , refer to the Engineers Program – Para. 5.7.3 for full details.
3. The required ingredients for each vend are delivered to the mixing bowl, where they are blended with hot water by a high speed whipper prior to discharge at the dispense head.

4. To ensure a free flow of ingredient powder and granules, it is essential that they are kept completely dry. This is achieved by extracting steam from the mixing system using an extract fan. The electrical supply for the extract fan is 230V AC.

N.B. The fan runs continuously whilst the machine has power.

5. Espresso machines: Coffee beans are stored in a bean container and are dispensed into the CoEx® Brewer via a 230V AC grinder located under the bean container outlet.

The amount of beans dispensed from the container is controlled by the vending machine controller and may be adjusted via timing constraints set in the Engineers Program.

7.4 Mixing System

1. The mixing system utilises 24V DC 13,000 RPM motor assemblies and mixes ingredient with hot water from the heater tank.
2. The mixing units are front mounted and secured by a single fixing screw. For servicing the complete unit can be quickly and easily removed.

7.5 Moving Dispense Head

1. Voce machines are fitted with a moving dispense head mechanism. This allows for a quicker and more direct cup drop and also helps to prevent cross contamination of drinks. The head features two separate dispense positions depending upon the drink being dispensed.
2. The mechanism is operated by a 24V DC 48 RPM motor. The motor is connected to a pinion which engages with a rack on the dispense arm. This mechanism is used to move the dispense head backwards and forwards.
3. A micro switch, fitted to the rear of the dispense head chassis detects the home position (head withdrawn/not dispensing). An optical sensor is also fitted and this works in conjunction with a decoder bracket attached to the rack to determine the position of the dispense head.
4. A moulded dispense head mounted at the front of the unit connects the tubes from the various mixing systems, brewers and hot water to separate dispense nozzles.

N.B. Dispense pipe lengths are shown in Section 9.

7.6 Cup Dispense Unit

1. Cups (either paper or plastic) are stored in tubes which are located above the cup dispense unit. The unit incorporates a 24V DC motor for indexing the correct turret over the cup drop unit as required.
2. The cups are separated and 'dropped' by a cup ring. The cup ring comprises five separator cams operated by a 24V DC motor which is controlled by the vending machine controller.

3. The cup level is monitored by an electronic system. An infrared LED (cup sensor transmitter) is positioned in the cup assembly above the cup splitter with an infrared detector (cup sensor receiver) mounted directly opposite.
4. The light emitted by the LED is detected when NO CUPS are present. With a stack of cups present, the beam is broken. As the cups drop below the LED transmitted light is detected. If this is the case, the controller will index the cup tubes until a full stack is located. A turret location micro- switch ensures that the cup tubes stop centrally over the cup ring.

N.B. The turret motor will run until the next stack is deposited into the cup splitter. This breaks the LED beam and the cup stack micro switch returns to its normally open state. The motor will run until it either finds the next stack or all the turret extrusions have been checked. If no cups are present the “Out of Cups Please Insert Mug” message is displayed on the LCD.

5. The cup stack index motor is protected by a time-out feature. The motor will rotate for a maximum period of 60 seconds. If at the end of this period no cups have been detected the LCD will display the “Out of Cups” message.

7.7 Waste Level Probes

1. The waste level probes are positioned in the waste bucket and detect the water level in the bucket.
2. The system consists of two probes in a moulded body. When the water level is high enough that both of the probes are immersed in the water a message is displayed on the LCD indicating the waste bucket is full and the machine is disabled. The machine will remain in this state until the waste bucket has been emptied.

7.8 CoEx® Brewer (Espresso Machines)

The unique CoEx® combined coffee and espresso brewer provides both freshly brewed coffee along with fresh coffee from beans through the same unit. The unit is driven by a 24V DC, 13 RPM motor controlled by a micro switch. The switch sends logic signals to the controller during vend and initialise operations, indicating its position.

Please refer to Section 7 for full details of the CoEx® brewer and its operation.

7.9 Oltre Brewer

Machines may be fitted with either one or two continuous belt Oltre brewers. The chamber, base plate, filter belt and outlet elbows are different depending on whether you are vending leaf tea or ground coffee.

Two 24V DC 30rpm motors are used on each of these brewers, one to raise and lower the brewer chamber the other to advance the filter belt. A cam operated micro switch signals to the Main Controller whether the chamber is open or closed.

7.9.1 Coffee Brewing

1. The coffee outlet elbow and baseplate are colour coded yellow and the belt is white (with black stitching).
2. The chamber clamps down onto the base plate and filter, water and coffee is then dispensed. After the brew time (set in program) has elapsed a 24V DC peristaltic pump draws the coffee liquor through the filter and is pumped to a whipper chamber where it can be whipped if required before being delivered into the cup.
3. The chamber now lifts and the second motor drives the filter belt and the waste is scraped into the waste bucket.

7.9.2 Tea Brewing

1. The tea outlet elbow and baseplate are colour coded blue and the belt is white (with white stitching).
2. The chamber clamps down onto the base plate and filter, water and tea leaves are then dispensed. Gravity draws the tea through the filter and it is delivered into the cup.
3. The chamber now lifts and the second motor drives the filter belt and the waste is scraped into the waste bucket.

7.10 Power Supply Units

1. The main power supply unit (PSU) provides power to the machine. It is mounted in the top right hand side of the machine and can be accessed by removing the top RH panel.
2. The PSU converts 230V AC to 24V DC to run the valves, whipper motors, ingredient motors, brewers, etc. fitted to the machine. The solid state relay is mounted on the PSU chassis and uses a 24V DC switching circuit to provide 230V AC for the heater element.
3. A secondary PSU converts 230V AC to 12V DC to power the screen and associated LEDs.
4. The Input/Output (I/O) board, mounted on the PSU chassis, utilises signals from the main controller in order to operate valves, whipper motors, dispense head motor, ingredient motors, brewer motors, etc.
5. The PSU houses the three fuses. These are as follows:
 - Heater, 12 amp (T) (ceramic) - Gravity boiler / Espresso boiler - (MDA 12A)
 - 240V Auxiliary, 4 amp (glass) - (MDA 4A)
 - 24V DC Output, 3.2 amp (T).

7.11 Mains Filter

A mains filter, mounted on the rear panel, it prevents spurious voltages generated by the machine from reaching the mains supply.

7.12 Coin Mechanism Transformer (Optional Extra)

The coin mechanism transformer converts 230V AC to 24V AC for Executive protocol type coin mechanisms and cashless systems.

7.13 Coin and Card/Key Systems

These machines may be equipped with coin or card/key validation systems using either protocol 'A' or an MDB system. The coin or card/key system informs the vending machine controller of the amount of credit which has been deposited into the vending machine.

7.14 Change Giver

1. The Change Giver which validates the coins communicates with the vending machine controller through a serial communication interface.
2. Once sufficient credit has been accumulated a vend will be permitted. Where possible the change giver will return the appropriate amount of change to the consumer.

7.15 Card/Key System

1. The card system fitted to the machine communicates with the vending machine controller using the same principle as the change giver.
2. The card system informs the vending machine controller of the amount of credit on the consumer's card. If there is sufficient credit for the selected drink the vending machine controller permits a vend and informs the card system of the amount of credit to be taken from the card. The new balance will then be re-written onto the consumer's card.

N.B. For full information and programming instructions for all of these systems please refer to the user manual supplied with the validation system.

Section 8 - Espresso System

Espresso machines are capable of producing high quality espresso based drinks through the unique CoEx® brewer unit either independently (Espresso, Americano) or in conjunction with soluble product (Cappuccino, Caffe Mocha etc). The machine will also vend high quality freshbrew coffee from pre-ground product.

8.1 Example Vend

When an Espresso drink is selected the following sequence occurs:

1. The consumer selects an espresso drink. Fresh beans are delivered into the grinder and the grinder is operated for a pre-determined time. Ground coffee is deposited into the CoEx® brewer.
2. The brewer moves to the vend position. The brewer motor starts running clockwise causing the filter assembly to cover the piston chamber and the piston to move upwards, forming the ground coffee into a compressed pellet as it does so.
3. When the heater reaches the correct temperature the inlet valve is opened and the 3 bar pressure relief valve closed. At the same time the pumps will start pumping water through the system and into the brewer.
4. Whilst water is passing through the system a water flow meter will send pulses back to the main controller and the espresso selection will be delivered into the cup.
5. Once the required amount of water has been pumped through the system the inlet valve closes and the pumps stop pumping water through the system. The brewer compresses the used coffee pellet, the pressure relief valve is opened and the espresso valve switched off.
6. The brewer motor reverses and drives the piston back up to the top of the chamber. The wiper mechanism ejects the used coffee pellet into the dry waste container and the brewer piston moves back to the stand-by position.

8.2 System Overview

Important: The machine must be operated in conjunction with a water filter of food grade quality. The filter must be capable of removing temporary hardness (scale), heavy metals (lead, copper, iron, cadmium), chlorine and any organic pollutants/discolouration. Crane Merchandising Systems recommend the Brita AquaQuell water filter for use with Espresso machines.

1. Water Inlet Valve

A 24V DC single solenoid water inlet valve. When a drink is selected the inlet valve is opened. At the same time the pumps are operated, pumping water through the system.

2. Reducing Valve

An inline reducing valve that maintains water pressure entering the system at:

- 0.9 bar—single pump system.

3. Flow Meter

As water flows through the system, the flow meter sends pulses back to the control board.

4. Vibration Pump/s - 230V AC

When a drink is selected the pumps switch on at the appropriate moment until the required amount of water has been pumped through the system.

5. Pressure Boiler

The pressure boiler has a capacity of 350ml and is fitted with a 2kW heating element. Cold water is diffused as it enters the boiler through the lower coupling. Heated water exits the boiler through the top coupling. A resettable temperature cut-out is mounted externally near the top of the boiler as a safety feature. A thermistor is mounted in the front of the boiler to measure water temperature.

6. Espresso Valve (3 way)

Supplies heated water to the CoEx® brewer when an espresso or freshbrew drink has been selected.

7. Pressure Valve (2 way)

This valve is normally open exposing the system to the 3 bar mechanical relief valve. It is closed during vends to allow higher pressures to be achieved within the system.

8. Relief Valve - 3 Bar (Mechanical)

The 3 bar pressure valve is a mechanical safety valve. The valve allows for heat expansion while the machine is in stand-by mode.

9. Grinder Mechanism (Not Shown On Water Flow Diagram)

The grind mechanism consists of a 230V AC conical grinder with a manual adjustment. When an espresso based drink is selected the grinder will run for the programmed time, grinding beans and feeding the brewer at the same time. The grinder is fitted with a manual adjusting mechanism which allows the engineer to vary the size of the ground coffee in order to satisfy consumers' taste preferences.

10. CoEx® Brewer (Not Shown On Water Flow Diagram)

The brewer unit is capable of receiving between 5 and 9 grams of ground coffee. Once the coffee has been ground and dispensed into the brewer unit the 24V dc brewer motor drives the brewer to the vend position using the current sensing as control. The coffee is compressed into a round 'cake' and water is pumped through the brewer. When the required amount of water has passed through the brewer the now wet coffee 'cake' is squeezed, removing most of the water from the 'cake' and preventing the brewer becoming unnecessarily dirty. After the 'cake' has been squeezed the brewer will deposit the cake into the dry waste container and return to the stand-by position.

8.2.1 Water Flow Diagram

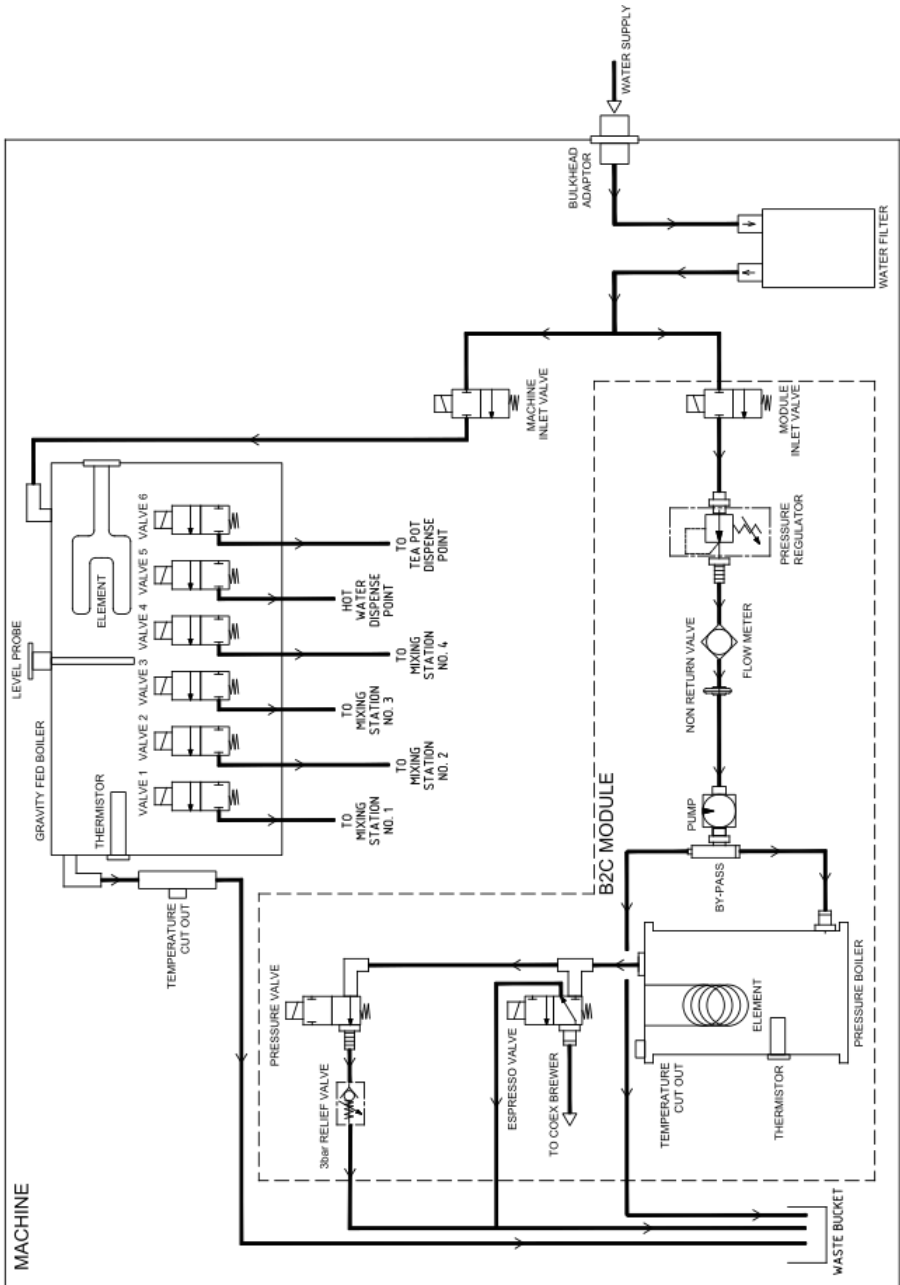

NOTE:
SYSTEM SHOWN IN IDLE STATE

Section 9 - Dispense Pipe Lengths

There are three sizes of pipe used on an COTI/CALI/ICON machine which can be replaced by the Operator:

- CoEx Espresso Brewer = 4mm white silicone.
- All others = 6mm.

9.1 To replace pipes

1. Open cabinet door and extend the delivery head by pressing 8 on the service keypad.
2. Using the above information about pipe size, connect the pipes to the dispense head. The numbers on the diagram below indicate which mixing bowl/brewer should be connected to which nozzle.
3. The pipes should be cut to such lengths that when the head is in this extended position they are not too taut and neither does the pipe sag below the delivery head.

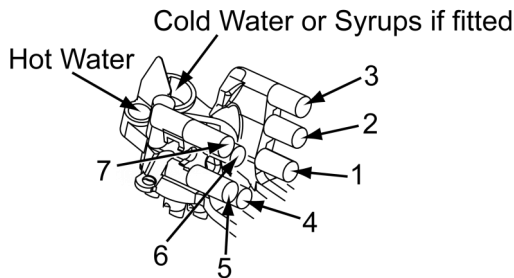

N.B. Soups must be connected to 1 or 4

Section 10 - Diagnostics and Maintenance Procedures

10.1 Diagnostics

The following pages list the error messages that may be displayed, diagnostics messages accessed via the engineers program and fault descriptions. For further help and advice please contact the Crane Merchandising Systems Technical Support Helpline on 01249 667323.

Error Message	Fault Description	Additional information
No Monetary Device	Machine is configured for an incorrect monetary device, or the device is not responding.	This error will move the machine out of service as there are no zero priced or free vend items so vending is not possible.
Coin Mech No Comms	Communication error detected between Coin Mech and machine.	
Coin Mech ROM Error	MDB coin mech ROM checksum test failed (fatal error).	
Coin Mech Acceptor Unplugged	MDB coin mech is unplugged or faulty.	
Coin Mech Acceptor Jammed	Coin jam detected in coin acceptor.	
Coin Mech Payout Jammed	Coin jam detected in coin tube.	
Coin Mech Sensor Error	Coin tube sensor fault detected.	
Coin Mech All Tubes Error	No useable coin tubes. Machine unable to pay out.	
Coin Mech Tube Error	Problem with coin tube. Tube indicates full, but coin count is zero.	
Coin Mech Disabled	Coin Mech has been disabled.	
Exec Price Error	The maximum price on the machine exceeds the maximum price that the Executive device can support.	

Error Message	Fault Description	Additional information
No Monetary Device	Machine is configured for an incorrect monetary device, or the device is not responding.	There is at least one zero priced item or free vend item so vending is possible.
Coin Return Motor Drive Failure	Failed to operate "Coin Return" motor.	Coin mech will be disabled if this error occurs. As the machine is now unable to operate coin return lever on the coin mech.
Use exact change	The amount of available change is lower than the Low Change Message setting.	
Cup turret switch	Error in turret assembly of cup drop unit while searching for a new cup stack.	Cup drop unit will be disabled once this error is set.
Cup turret switch timeout	Turret switch was not released within the given timeout.	Potential error with Turret switch. Machine will disable the cup drop unit once this error is set.
Cup mechanism peeler motor/switch failure	Error in cup peeler assembly of cup drop unit	Unable to see micro-switch transition within the timeout period. The machine will not attempt to drop any further cups once this error is set.
Searching For Cup Stack	Cup drop unit is currently searching for cups in the turret.	This error will be removed once the search operation is complete. The machine will operate in "Mug only" mode while this error is active.
No Cup Delivered Ring 1 SureVend On	Cup drop unit failed to drop a cup after 9 attempts (3 attempts per vend).	This can be a result of cups jammed in the cup drop unit or faulty sure vend sensors.
Please insert mug	Machine is only able to operate in mug only mode due to sure vend or turret errors.	If the machine was unable to detect a cup in the cup station after trying 9 times (3 tries per vend) to drop a cup, then it will raise this error. This error will also be raised if the turret operation failed.
Mug only mode	Machine will only allow mug vends.	If there is a Cup Peeler error or if Cup drop unit is completely disabled then this error will be raised. The machine will still be operational, however, it will not drop a cup and will only allow mug vends.

Error Message	Fault Description	Additional information
Mug Sensor SureVend Error	Mug sensor blocked since bootup.	If there is nothing present in the cup station. Then, either the mug sensors are misaligned or sensors are faulty. The machine will be taken out of service if this error occurs. This error will be cleared once the above mentioned issues are fixed.
Dispense Head Not Homed	Dispense head home operation failed.	Machine will be taken out of service, as the machine can no longer dispense a drink. This error is normally a result of faulty home switch.
Dispense Head Not Extended	Dispense head extend operation failed.	Machine will be taken out of service as it can no longer dispense any more drinks. This error is normally a result of faulty opto sensor.
Dispense Head Motor Not Enabled	Dispense head unable to move at all.	If the software is unable to detect any activity on opto sensor then it will raise this error. The error can be down to faulty motor or faulty opto sensor.
Brewer Jam	Unable to detect switch input in the given time out for Uni-Paper or Oltre paperless brewer present in the machine.	This will disable all drinks based on this particular brewer.
Brewer Waste Pail Full	Brewer waste capacity is exceeded.	This error will only be raised if brewer waste management is enabled. It will disable all fresh brew drinks. The drinks will only be enabled after the counters are reset from the service menus.
Brewer Jam (CoEx®)	Error while operating the CoEx® brewer.	Motor is stalled or is taking more current than the allowed limit.
Water filter replacement required	Overall water filter usage has exceeded the set limit. Water filter needs to be changed.	This error is only raised if water filter counters are enabled. Once the error is raised no further drinks could be taken until the counter is reset from service menus.
Water Tank Leak	Main Boiler is experiencing water leakage.	This error is raised if the main boiler requests fill operation 15 times even though none of the valves attached to it were operated.
Low Water	Main boiler is running low on water.	This error will be cleared once main boiler is filled up.

Error Message	Fault Description	Additional information
No Water Available	Main boiler unable to fill up in required amount of time.	The error will be raised if the fill operation continues for more than 20 seconds. However, if the machine is able to successfully complete the fill operation within 2 minutes then it will remove this error. No further drinks can be taken once this error is set.
Waste Pail Full	Waste bucket is full.	Waste bucket needs to be emptied. Once this error is set the machine will not re-attempt to fill the water tank until the operator goes in and out of service menus.
Please Wait	Transition based on door switch is in progress.	This is displayed while moving from Service Mode to Consumer UI or from Consumer UI to Service Mode.
No IO Comms	I/O Board went through a reboot.	This error will be cleared by the software if it is able to successfully reconfigure and re-initialise the I/O board.
No IO Comms 2	VMC unable to establish communication with the I/O board.	This error will be cleared by the software if it is able to successfully re-initialise the I/O board.
No Selections Available	No selections available on the machine.	Usually a result of incorrect machine id, configuration id or Cup Size being set on the machine.
All Selections Disabled	All drink selections have been disabled.	The machine is taken out of service as none of the drinks could be dispensed.
Invalid Temperature Tank 1	Water temperature recorded in main boiler is way beyond operational range (0C to 125C).	The error is normally down to a faulty temperature probe. All hot drinks using main boiler will be disabled. The error will be cleared when valid temperature reading is obtained.
Invalid Temperature Tank 2	Water temperature recorded in pressure boiler is way beyond operational range (0C to 125C).	The error can be generated in the following three scenarios: <ol style="list-style-type: none"> 1. Faulty Temperature probe. 2. Very fine coffee grind which is restricting the water flow. 3. Too much coffee put in the chamber which is restricting the water flow. Machine will disable all CoEx® based drinks when this error is raised. The error will be cleared when valid temperature reading is obtained.

Error Message	Fault Description	Additional information
Card Reader No Comms	The MDB card reader is not responding to commands.	
Card Reader Manuf Trans Error	The card reader reports that there is a manufacturer's transient error.	
Card Reader Comms Error	The card reader reports that there is a communications error.	
Card Reader Service Error	The card reader reports that there is a service error.	
Card Reader Manufact OOS Error	The card reader reports that there is a manufacturer's error and out of service.	
Bill Validator No Comms	The bill validator is not responding to commands.	
Bill Validator Motor Error	The bill validator is reporting a motor error.	
Bill Validator Sensor Error	The bill validator is reporting a sensor error.	
Bill Validator ROM Error	The bill validator is reporting a ROM error.	
Bill Validator Acceptor Jammed	The bill validator is reporting that the acceptor is jammed.	
Bill Validator Stacker Error	The bill validator is reporting a stacker error.	
Bill Validator Stacker Full	The bill validator is reporting that the stacker is full.	
Bill Validator Disabled	The bill validator is reporting that it is disabled.	
Water heating	Water temperature in main boiler is below operating temperature.	The error is cleared once operating temperature is achieved by pressure boiler. The machine will disable all hot drinks using main boiler if the temperature falls below min vend temperature. The drinks will be re-enabled once min Vend temperature is achieved.

Error Message	Fault Description	Additional information
Power save mode	Machine is in power save mode.	Water in both the boilers is maintained at a lower temperature to conserve power.
Boiler heating	The machine is heating up the boilers while coming out of power save mode.	This message will be removed once operating temperature is achieved in both the boilers.
SANITATION_EVENT_FAILED	Failed to complete the sanitation successfully.	
Please wait, Cleaning In Progress	Automatic or manual rinse cycle is in progress.	The error is cleared up once sanitation process is complete.
Water heating (CoEx®)	Temperature in pressure boiler is below operating temperature.	The error is cleared once operating temperature is achieved by pressure boiler. The machine will disable all CoEx® based drinks if the temperature falls below min vend temperature. The drinks will be re-enabled once min Vend temperature is achieved.
No Water (CoEx®)	Unable to see minimum required flow when dispensing water from pressure boiler.	All drinks related to pressure boiler will be disabled.
Low Water (Cold)	Cold unit tank is low on water.	The error is cleared when cold unit tank is filled up.
No Water (Cold)	Cold Unit was unable to fill up in the allocated time.	All cold drinks will be disabled.
Cleaning Required (CoEx®Brewer)	It's been at least 7 days since last CoEx® clean. This error will also be raised if last clean was interrupted in the middle.	The error is advisory from day 7 to 10 unless the error was raised as a result of interruption of the last CoEx® tablet clean. However, on day 10 the software will disable all CoEx® based drinks, until the clean is performed.
No Coffee	One of the ingredients used with CoEx® brewer has run out.	Beans hopper or pre-ground coffee canisters attached to CoEx® brewer needs to be refilled. All drinks using this ingredient will be disabled.
Preparing brewing system	Pre-heat rinse is in progress.	This is a transient error. Only shown when pre-heat rinse is in progress. Automatically cleared by software after the rinse is successfully completed at the start of the vend.

10.2 Heater Tank De-Scale Procedure

To maintain correct water levels and water temperature the heater tank must be inspected regularly and if necessary be de-scaled. To ensure long and trouble-free operation Crane Merchandising Systems recommend that all machines have a water filter fitted.

There are a number of ways of de-scaling the heater tank. The tank can be removed and scraped out with a blunt tool but it can also be left inside the machine and a de-scaling agent introduced into the tank. This eliminates the need to remove the thermistor, water level probe and all the outlet valves from the tank saving time and money. Always remember to fit a new water filter and boiler seal after de-scaling.

Use the following steps as a guideline only and always refer to the instructions supplied with the de-scaling agents regarding dosage and de-scaling time.

1. Switch off the machine and open the door. Remove all canisters and back covers.
2. Using the drain hose fitted to the tank remove the bung and drain the water from the heater.



Safety First! Allow the water in the tank to cool before draining.

3. Once all of the water has drained from the tank replace the bung into the drain hose. Introduce the de-scaling solution in the recommended dosage into the heater tank on the machine and allow the heater tank to fill.
4. Turn off the machine and leave for approximately 40 minutes before draining the tank again following the sequence described above.
5. Fit a new water filter and switch on the machine. Fill the tank and drain again until all traces of the de-scaler are removed (at least 3 times).
6. Switch on the machine and allow the heater tank to fill and to heat up. Drain and fill one more time. The machine is now ready to be put back in service.

10.3 System Drain Down - Espresso Machines Only

Should it become necessary for the engineer to do any work on the Espresso water system it is very important that the following sequence is followed to ensure safe working as well as correct system fill and heating when the machine is powered up.

10.3.1 Cooling down the Espresso system

1. Open the front door of the machine. Using the service keypad located in the rear of the door press the 'Machine Cool Down' button (10) to ensure the system is cooled. Approximately 600ml of cold water is flushed through the system and out to the waste bucket.



Important: Pressing button 10 also informs the machine software that the Espresso system has been drained ensuring that the Espresso system will automatically fill before heating on power up. This is very important and must not be overlooked.

2. Once the Espresso system has been cooled the LCD will display the message 'Machine cooled' and water will stop pumping through the system. Remove the waste bucket and empty the contents before re-fitting to the machine. Ensure all pipes etc. are refitted correctly into the bucket.

10.3.2 Draining down the module

Draining down the module allows the engineer to safely work on system components. It may also be necessary to do this for transit purposes.

N.B. A cool down cycle **MUST** be carried out before draining the module.

1. Remove the lower cover from the module to expose the boiler blanking plug (3). Hold the collar and remove the plug. Attach a length of silicone pipe to the outlet to act as a drain tube and place the other end into a bucket.
2. When the module is completely drained, remove the drain tube from the outlet.

Replace the blanking plug (3) and lower cover.

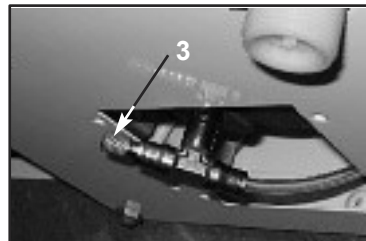

10.3.3 Removing the module for maintenance

N.B. It is not necessary to remove the module to drain the system down.

To remove the module for maintenance proceed as follows:

1. Close the fresh beans outlet slide and remove the fresh beans container along with the fresh ground coffee canister. Loosen the screws securing the RH boiler cover and remove. Unclip the two loom connectors to the Espresso module.
2. Remove the brewer waste bucket from the machine. Turn off the water supply to the module using the cut off (1) located in water pipe situated under the module. Un-screw and remove the water inlet hose (2) to the module.
3. Loosen the two lower Espresso module retaining screws and carefully lift the module up and out of the machine.
4. Turn off the power to the machine.

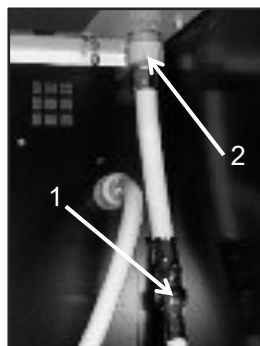

10.3.4 Refitting the module and refilling the system

To refit the module and refill the system, proceed as follows:

1. Carefully re-install the module into the machine. Tighten the 2 lower module fixing screws, refit the top LH retaining screw, plug the two loom connectors into the module connectors and re-fit the water inlet hose.
2. Refit the RH boiler cover, fresh ground coffee canister and fresh beans container. Ensure fresh beans outlet slide is opened.

10.3.4.1 Long fill cycle

1. Turn the power on to the machine, it will initialise, performing a long fill cycle. During this cycle 550ml of cold water is pumped through the system and collected in the waste bucket.
2. At the end of the long fill cycle the brewer initialises and the water in the boiler is heated.

10.3.4.2 Pre-Heat Routine

1. During the pre heat routine a small amount of hot water is pumped through the brewer system. The pre heat routine is performed prior to the first CoEx drink vended after powering the machine on or prior to the next Co-Ex drink vended after a 7 minute period of brewer inactivity.
2. The pre heat routine is only available on single pump units.

10.4 CoEx® Brewer/Bean Grinder Maintenance - Espresso Machines Only

Espresso machines are fitted with the unique CoEx® brewer unit which produces both fresh coffee and espresso based drinks from ground beans and freshbrew pre-ground coffee from the same unit. Routine cleaning and maintenance instructions for this unit can be found in the Voce Operators Manual - Part No. PR10908000.

10.4.1 CoEx® Brewer/Grinder Blades - 50,000 Vend Service

Crane Merchandising Systems recommends that the brewer unit and bean grinder is serviced by an authorised engineer after every 50,000 vends.

A CoEx® service kit (part no. PH11705000, shown opposite) is available from the manufacturer and contains all of the components required to ensure the machine continues to give trouble-free service.

The service kit contains the following components (with part nos.):

1. Lower piston and cylinder assembly – Pt. No. ME10592000
2. Filter head assembly - Pt. No. ME11703000
3. Grinder blades - Pt. No. ME07308000
4. 'O' ring - water inlet (not shown) - Pt. No. ME10595000



To carry out the 50,000 vend service, proceed as follows:

1. Disconnect the machine from the mains electricity.

Open the front door of the machine and remove the coffee dispense pipe from the brewer outlet.

Holding the unit as shown in the photograph, lift the green lever (a) and carefully pull the brewer unit out of the machine.

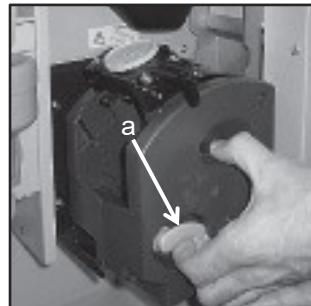

- Carefully unclip the wiper arm from the brewer unit and place to one side.

Remove the filter assembly from the brewer. Holding the filter assembly as shown, turn the locking ring anti-clockwise to its open position, indicated by the two arrows.

Carefully remove the old filter unit down and out of the CoEx® brewer unit. Discard the used filter unit.



- Remove the bolt securing the brewer drive coupling to the input shaft. Pull the coupling off of the shaft and place to one side.

Ensure that the captive lock nut is retained in the drive coupling moulding.



- Working from the front of the brewer, unscrew and remove the three retaining screws which secure the brewer unit together.

Carefully ease both the front and rear brewer panels away from the central piston chamber/ swing arms assembly.

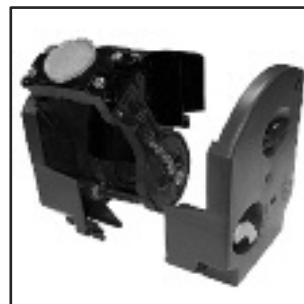

- Holding the unit as shown in the photograph, rotate the lower piston and cylinder assembly clockwise and then remove it up and out of the swing arms/filter holder assembly.

Discard the used lower piston and cylinder assembly.

Clean all of the dismantled brewer components thoroughly to remove all traces of waste coffee product.

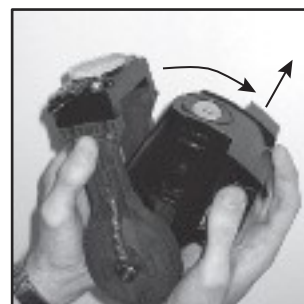

6. Take the new lower piston and cylinder assembly from the service.

Before assembling the unit to the swing arms/ filter holder assembly, ensure that the lower piston (a) is at the top of its stroke as shown in the photograph.

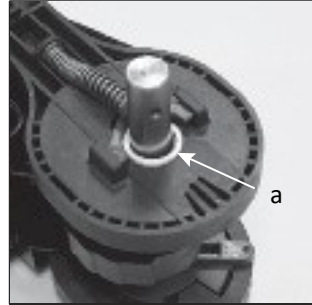

7. Ensure that the piston drive cam (b) is positioned as shown.

If necessary push the piston drive cam anti-clockwise until it reaches its stop position.

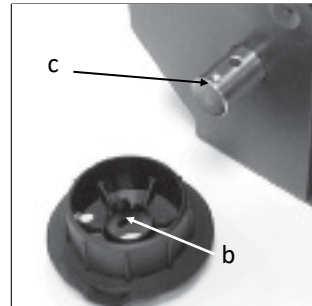

8. Holding the lower piston and cylinder assembly as shown, guide the assembly into the swing arms/ filter holder assembly.

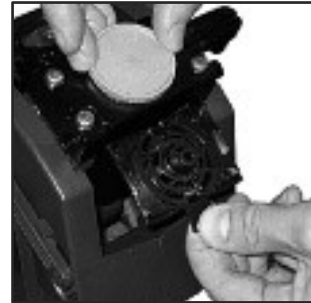

9. Check and ensure that the lower piston guide block (c) locates with the piston drive cam (d) as shown in the photograph.

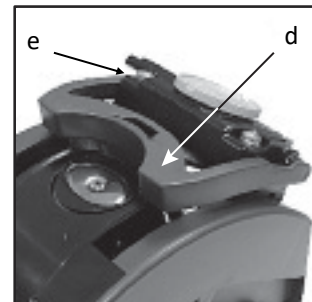

10. Ensure the plastic washer (a) if fitted is placed correctly over the input shaft (long side) as shown.
Re-assemble the front and rear brewer panels to the central piston chamber/swing arms assembly using the three retaining screws/locknuts. Check and ensure that the brewer release lever mechanism operates correctly.

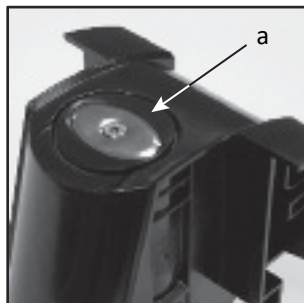

11. Re-fit the brewer drive coupling to the input shaft ensuring that the raised 'pip' (b) lines up with its locating dimple (c) on the input shaft.
Ensure that the captive lock nut is retained in the plastic drive coupling moulding. Refit the bolt to secure the brewer drive coupling to the input shaft.

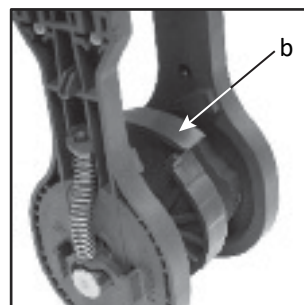

12. Take the new filter head assembly from the service kit.
Holding the new filter assembly as shown, turn the locking ring anti-clockwise to its open position, indicated by the two arrows.
Place the filter unit up into the filter holder and turn the green locking ring clockwise to lock it into place.



13. Re-assemble the wiper arm (d) to the filter holder assembly.
Ensure that the wiper arm is located under the coffee outlet pipes as shown (e).

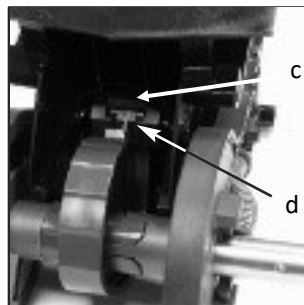

14. Moving to the machine remove the 'O' ring (a) from the water inlet pipe and discard. Fit the 'O' ring included in the service kit onto the inlet pipe. Ensure that the new 'O' ring is seated correctly.
- Refit the CoEx® brewer unit into the machine. Slide the unit into place until it 'clicks' into position. Refit the coffee dispense pipe to the brewer outlet.

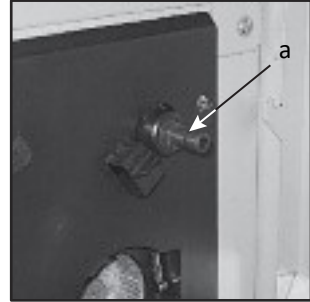

10.4.2 Replacing the Grinder Blades.

1. Isolate the machine from the Mains power supply.

Push in the bean canister shut-off to close the fresh beans outlet. Carefully remove the fresh beans canister from the machine and place it to one side.

Pull up and remove the grinder adjusting wheel assembly (b) from the rear of the grinder body.

Unscrew the grinder body (c) anti-clockwise and remove it from the blade housing.

Note: Grinder mechanism removed from the machine for clarity.

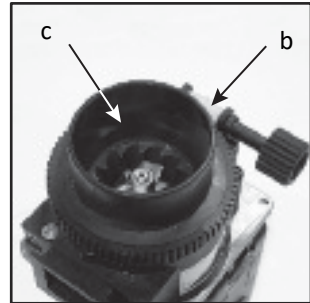

2. Unscrew and remove the nut, star washer and agitator (d) from the drive shaft.

Note: Nut is fitted with a left hand thread.

Remove the Grinder blade block (e) and discard. Replace with the new grinder blade block included with the service kit.

Refit the agitator, star washer and nut. Ensure that the nut is tightened securely.

3. Take the new grinder body complete with inner grinder ring from the service kit. Screw the grinder body clockwise into the blade housing until it stops.

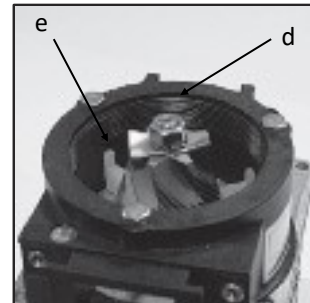

Re-set the grinder blades. An approximate starting position is achieved by turning the grinder body back one full turn anti-clockwise. Re-assemble the grinder adjuster wheel assembly to the grinder unit.

4. Refit the fresh beans container to the machine. Pull the bean canister shut-off to its fully extended position.
5. Turn on the electricity supply to the machine.



Important! Before returning the machine to service, the Grinder Calibration routine (refer to Section 5.7.3.1) must be carried out to ensure correct operation of the grinder with the type of beans used in the machine. Use the grinder adjuster wheel to fine tune the blade settings in order to obtain the desired grind quality.

Section 11 - Electrical/Electronics Information

The diagrams shown on the following pages illustrate the layout of and the connections between the electrical and electronic components within COTI, CALI and ICON machines. The following diagrams are common to all machines except where stated.

11.1 Touch Screen - COTI

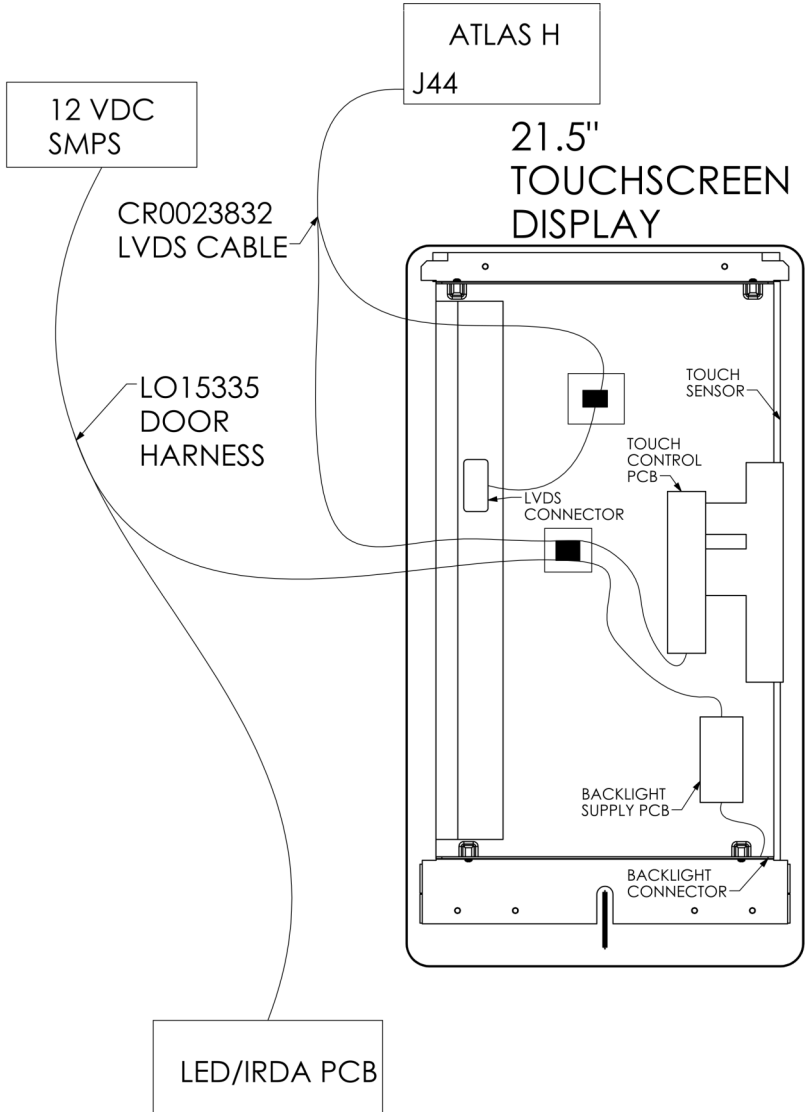

11.2 Touch Screen - CALI / ICON

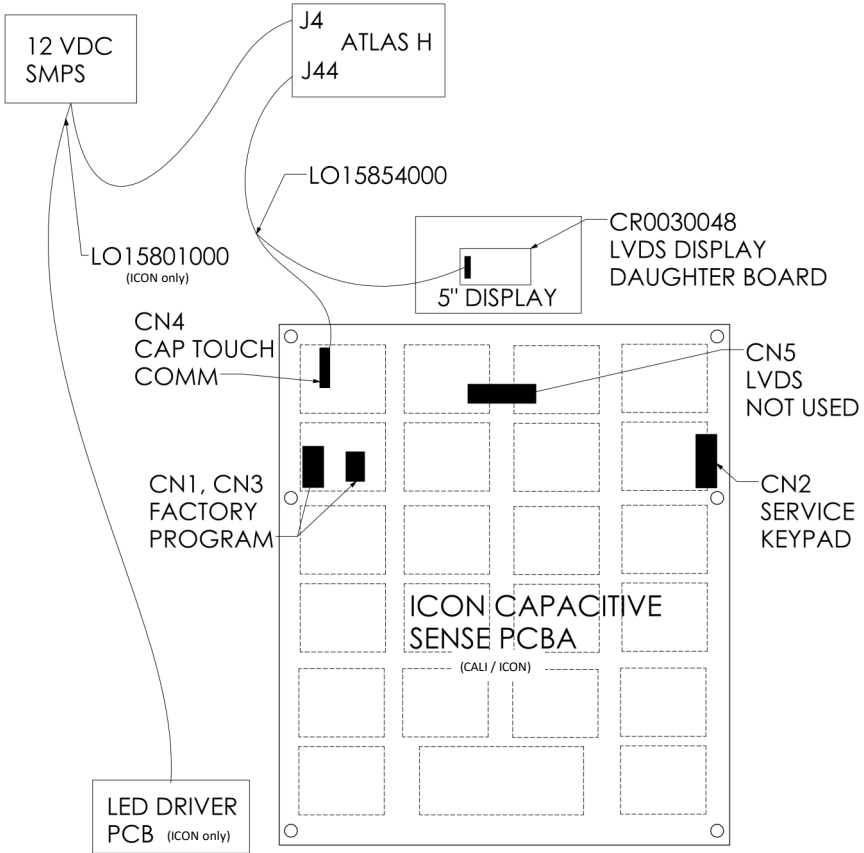

11.3 Control Board - Atlas H Board

The Control Board is the main controller for all of the machines functions. The board is located inside the door behind the monetary cover. To gain access to the board:-

1. Switch off the power to the machine and open the front door. Loosen the securing screws and remove the monetary cover.
2. Open the monetary cover. Unscrew and remove the two screws securing the control board cover. Carefully remove the control board cover.

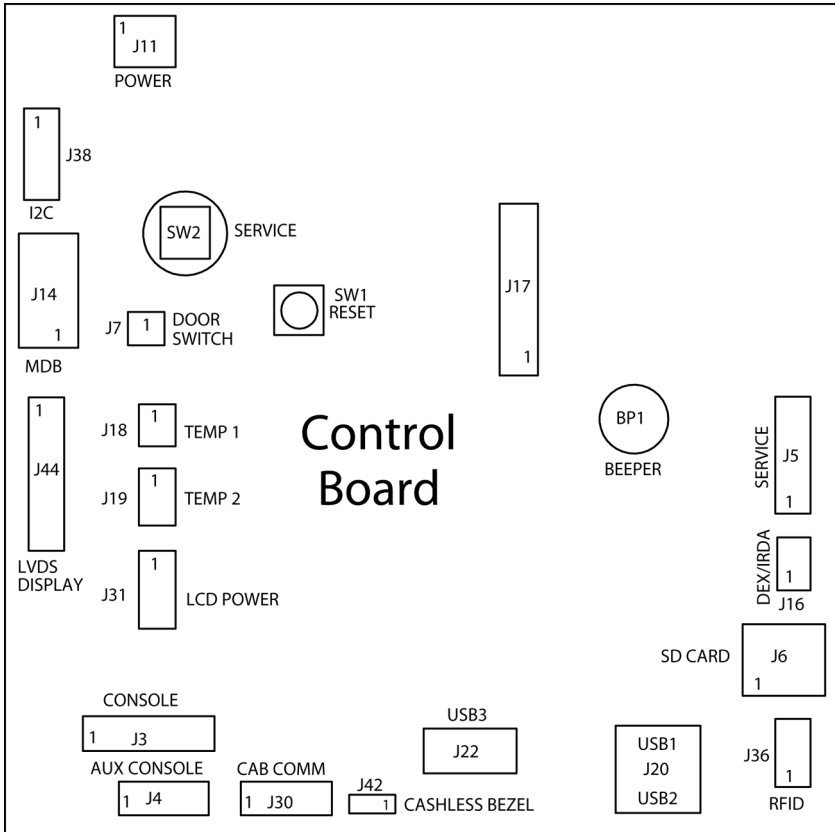

11.4 Control Board Connections - Atlas H Board

The diagram below and table opposite illustrate the connections between the control, IRDA and LED boards.

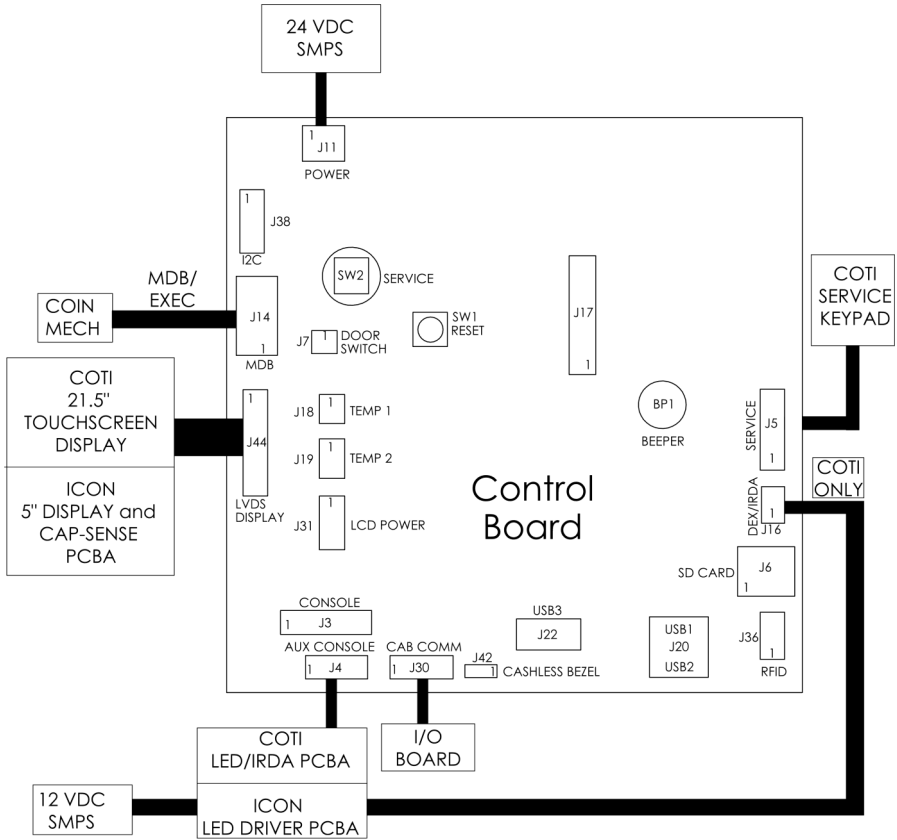

CONTROL BOARD CONNECTOR	WIRE COLOUR	TO CONNECTOR	FUNCTION
J4 PIN 1	BLACK	J2 PIN 1 LED/IRDA	LED (+5VDC)
J4 PIN 2	ORANGE	J2 PIN 2 LED/IRDA	LED (CLK)
J4 PIN 3	YELLOW	J2 PIN 3 LED/IRDA	LED (MOSI)
J4 PIN 4	GREEN	J2 PIN 4 LED/IRDA	LED (MISO)
J4 PIN 5	BLUE	J2 PIN 5 LED/IRDA	LED CS)
J4 PIN 6	RED	J2 PIN 6 LED/IRDA	LED (GND)
J5 PINS 1-8	CABLE ASSY	SERVICE	KEYPAD
J11 PIN 3	RED/BLACK	R1 PIN 2	SMPS (OV)
J11 PIN 4	RED/PINK	R1 PIN 1	SMPS (+24VDC)
J14 PIN 1	NOT/USED	EXEC/MDB OPTION	MDB (+5VDC)
J14 PIN 2	BROWN	EXEC/MDB OPTION	MDB (GND)
J14 PIN 3	BLUE	EXEC/MDB OPTION	MDB (Tx)
J14 PIN 4	YELLOW	EXEC/MDB OPTION	MDB (Rx)
J14 PIN 5	RED	EXEC/MDB OPTION	MDB (GND)
J14 PIN 6	WHITE	EXEC/MDB OPTION	MDB (24VDC)
J16 PIN 1	RED	J7 PIN 4 LED/IRDA	IRDA (+5VDC)
J16 PIN 2	GREEN	J7 PIN 3 LED/IRDA	IRDA (Rx)
J16 PIN 3	BLLUE	J7 PIN 2 LED/IRDA	IRDA (Tx)
J16 PIN 4	BLACK	J7 PIN 1 LED/IRDA	IRDA (GND)
J30 PIN 4	RED	H12 PIN 4 I/O BRD	I/O COMM (RESET)
J30 PIN 5	BLUE	H12 PIN 2 I/O BRD	I/O COMM (TxD)
J30 PIN 6	GREEN	H12 PIN 3 I/O BRD	I/O COMM (RxD)
J30 PIN 8	SCREEN	H12 PIN 5 I/O BRD	I/O COMM (GND)
J44 PINS 1-50	CABLE ASSY	21.5" DISPLAY	DISPLAY

11.5 Input/Output Board

The input/output board is located at the top RH side of the machine. It is mounted onto the rear of the cabinet and can be accessed by removing the ingredient canisters and the RH boiler cover.

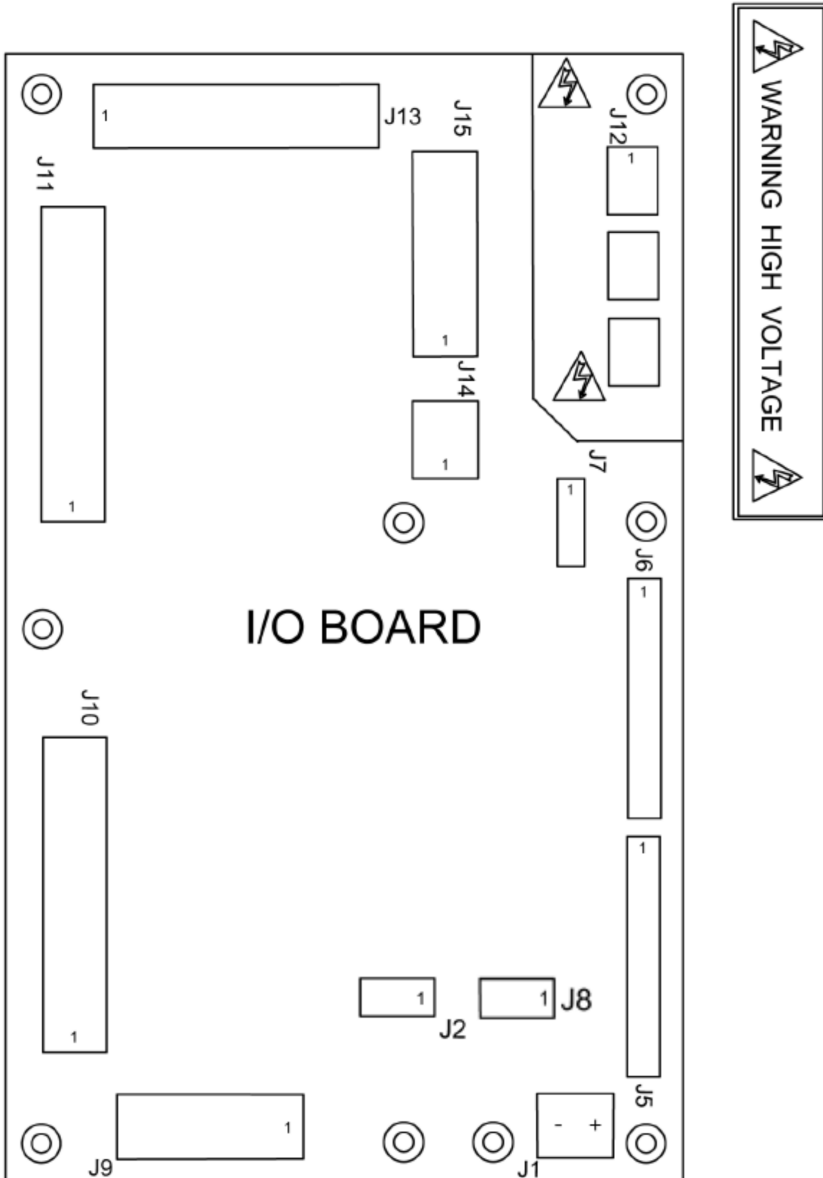

11.6 Input Circuit 1

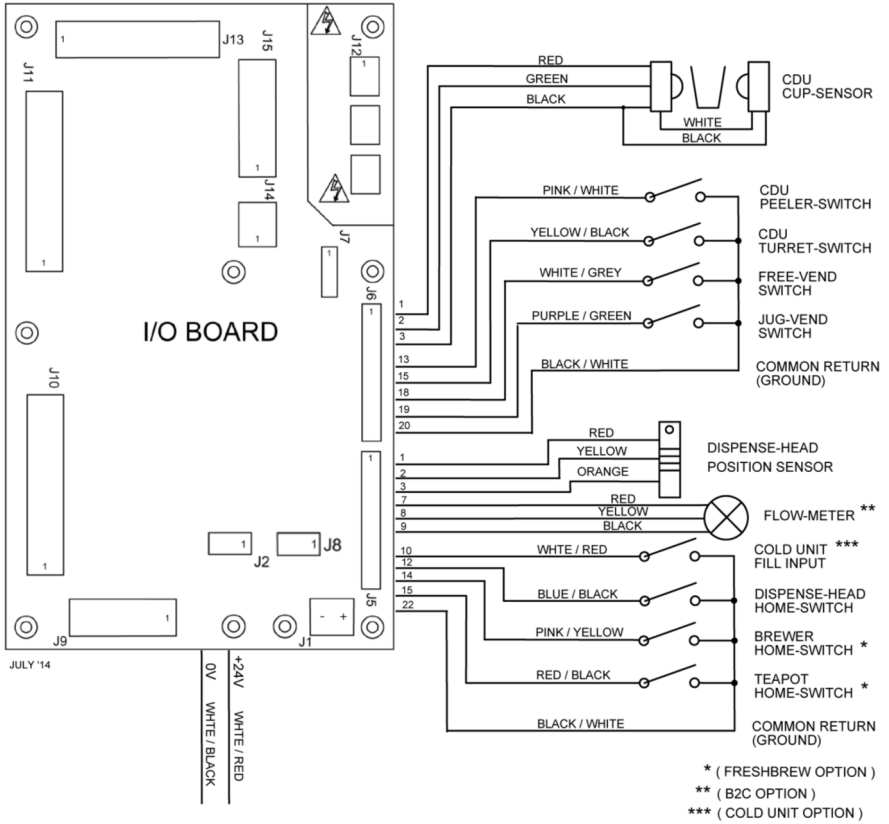

11.8 Output Circuit 1

- * FRESHBREW OPTION
- *** COLD UNIT OPTION
- # TEAPOT OPTION
- # BREWER OPTION
- § STIR-STICK OPTION

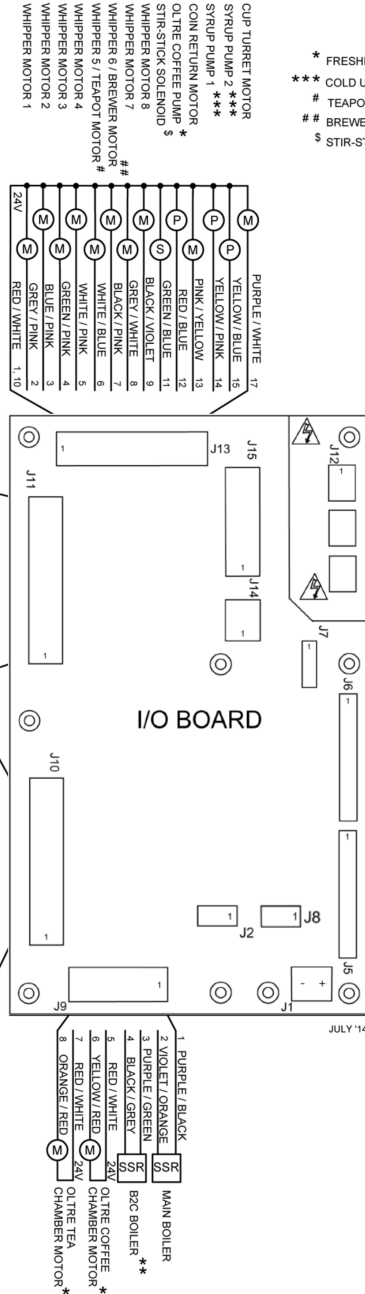

- CUP PEELER MOTOR
- INGREDIENT MOTOR 9
- INGREDIENT MOTOR 8
- INGREDIENT MOTOR 7
- INGREDIENT MOTOR 6
- INGREDIENT MOTOR 5
- INGREDIENT MOTOR 4
- INGREDIENT MOTOR 3
- INGREDIENT MOTOR 2
- INGREDIENT MOTOR 1
- B2C INLET VALVE **

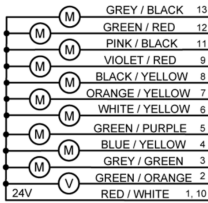

- PRESSURE RELIEF VALVE **
- ESPRESSO VALVE **
- DISPENSE VALVE 8
- DISPENSE VALVE 7
- DISPENSE VALVE 6
- DISPENSE VALVE 5
- DISPENSE VALVE 4
- DISPENSE VALVE 3
- DISPENSE VALVE 2
- DISPENSE VALVE 1
- OLTRE TEA BELT MOTOR *
- OLTRE COFFEE BELT MOTOR *
- STILL VALVE ***
- CARBONATOR VALVE ***
- COLD UNIT FILL VALVE ***
- INLET VALVE

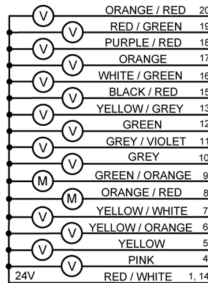

- * FRESHBREW OPTION
- ** BEAN 2 CUP OPTION
- *** COLD UNIT OPTION

JULY '14

11.9 Output Circuit 2

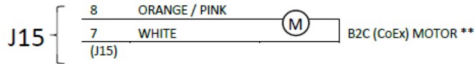
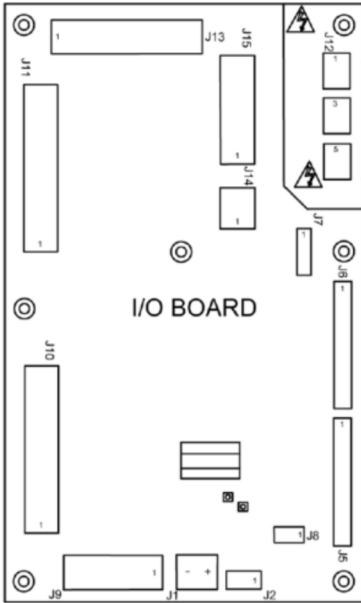

NOTE:
 PCB Connectors J14 & J15 are combined using 13-way
 harness connector H2.

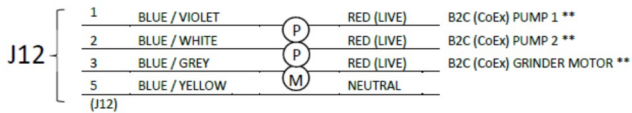
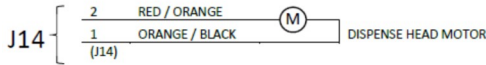

**BEAN 2 CUP OPTION

11.10 Power Circuit - Instant and Freshbrew Machines

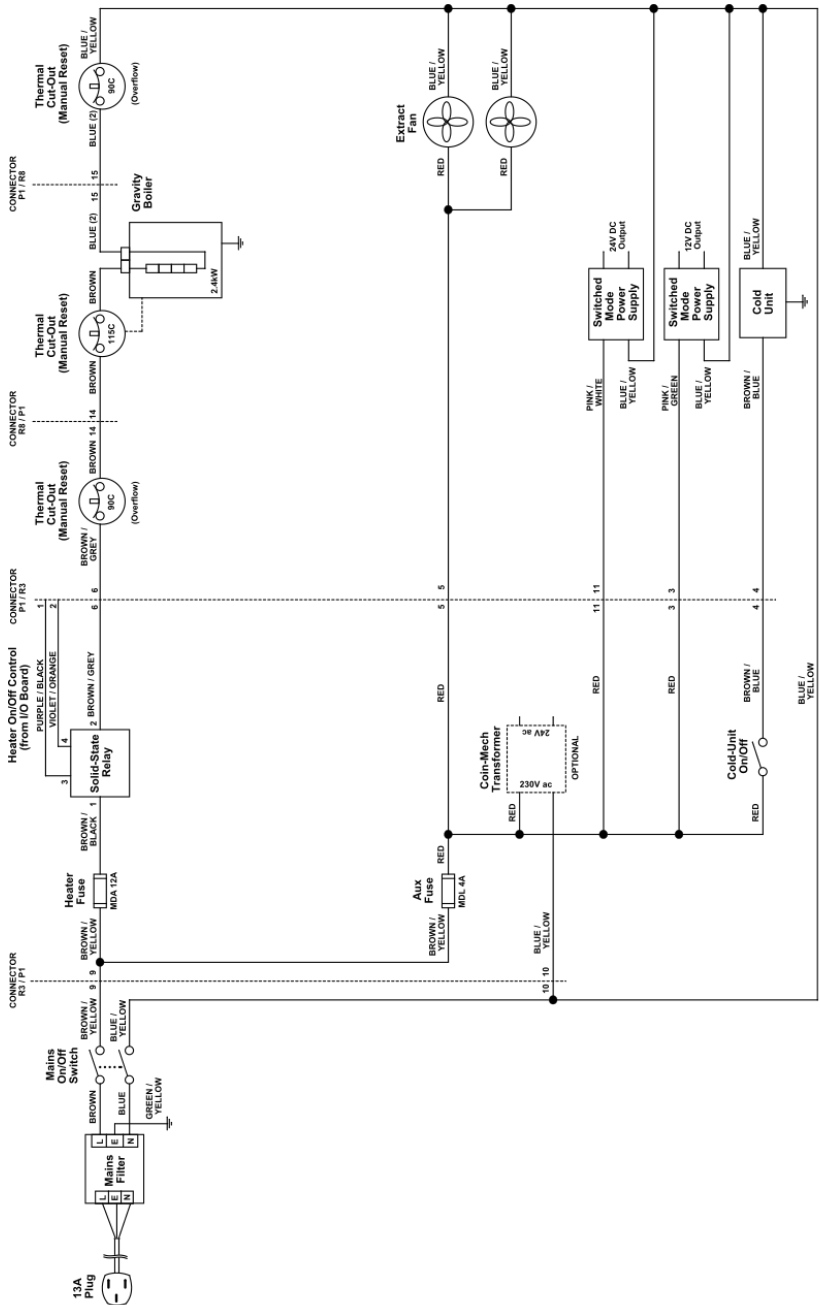

11.11 Power Circuit - Espresso Machines

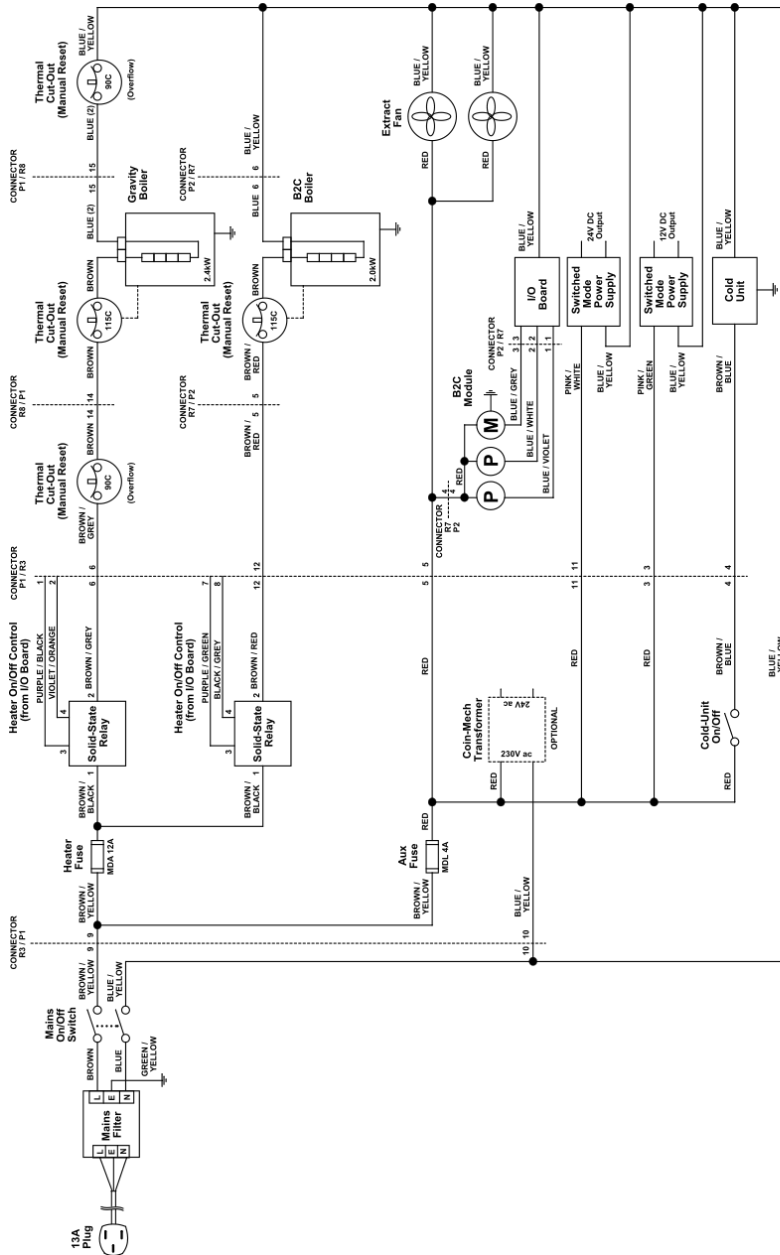



11.12 Heater Circuit

The water temperature in the Main Boiler and the Pressure Boiler (B2C machines) is controlled by a thermistor probe. This has a variable resistance – high resistance when cold, low resistance when hot. The thermistor probe is in contact with the water and continuously monitors the water temperature. At room ambient temperature the thermistor resistance is approx. 3000 ohms. At 96°C the thermistor resistance is approx. 200 ohms.

Both Boiler Heating Elements are controlled by Solid-State Relays which are in turn controlled from the I/O Board. The Main Boiler Element is rated at 2.4kW, the B2C Boiler Element is rated at 2.0kW.

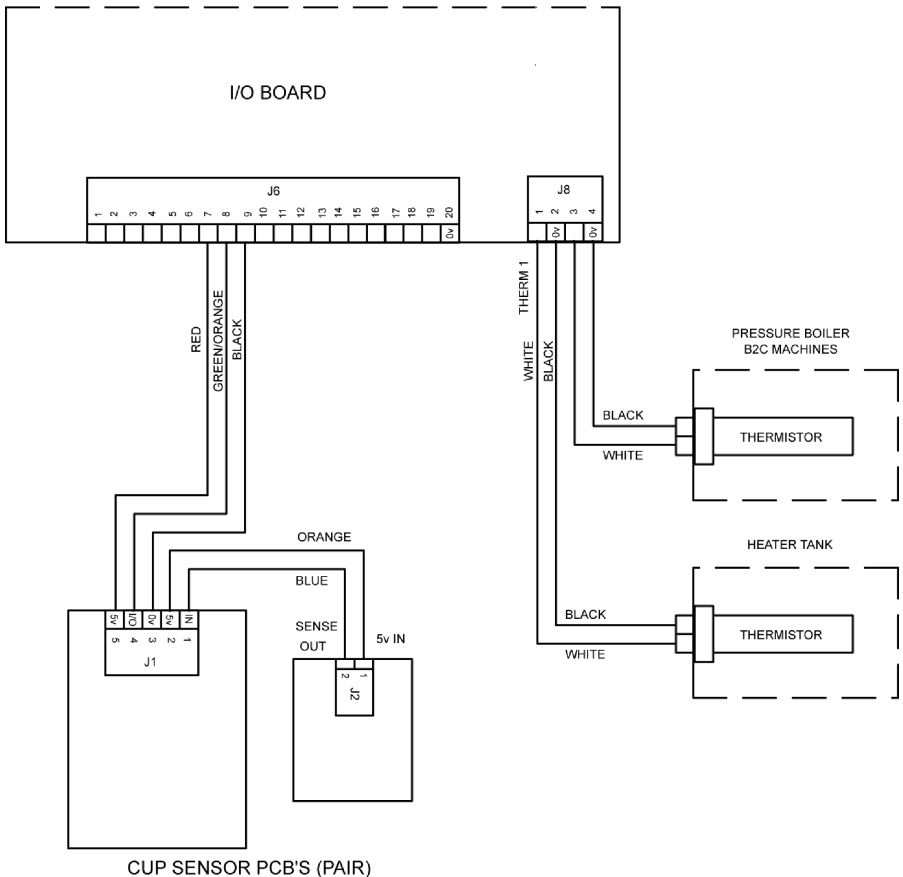
Should control of the Heating Elements fail for any reason, both Elements are protected by In-Line Manually Reset-able Thermal Cut-Outs. These are positioned in the overflow pipe of the Main Boiler (90°C), and on the casing of the B2C Boiler (115°C).





Visit the **Tech Zone** on our website to find this
and other manuals and technical information for
the complete Crane machine range.

www.cranems.co.uk/technical/

CRANE[®] MERCHANDISING SYSTEMS

Pipsmore Park, Bumpers Farm Industrial Estate,
Chippenham, Wiltshire, SN14 6NQ
Tel: +44 (0)1249 44807 Fax: +44 (0)1249 444819
Email: sales@cranems.co.uk
Website: www.cranems.co.uk